



User Manual

DNAKE Cloud Platform



Contents

1. Introduction.....	1
1.1 Introduction	1
1.2 Introduction of some icons	2
1.3 Supported devices and solutions.....	3
2. Login and Logout.....	10
2.1 Login and Logout.....	10
2.2 Forget password	12
3. Personal Center and System Messages.....	14
3.1 Basic information	14
3.2 Change Password.....	14
3.3 Login Settings.....	15
3.4 System Message	16
4. Distributor.....	18
4.1 Manage the device	18
4.2 Sub-Distributor	19

4.3 Reseller/Installer	24
4.4 License Log.....	28
4.5 My message	29
5. Reseller/Installer	31
5.1 Home page.....	31
5.2 Property Manager	31
5.3 Site	33
5.4 Device	55
5.5 License Log.....	64
5.6 Update-Firmware List (OTA).....	65
5.7 Update-Upgrade Log (OTA).....	66
5.8 My Message	66
5.9 Log	68
5.10 Switch to Property Manager.....	69
5.11 Technical Supporter	70
6. Property Manager	72
6.1 Home Page.....	72

6.2 Site	75
6.3 Access Control	87
6.4 License Log.....	100
6.5 Security Alarm.....	101
6.6 My Message	101
6.7 Log	103
6.8 Administrator	105
6.9 Advanced.....	109
6.10 Contact Technical Support.....	111
7. Appendix A:	112
American data center: (https://us-cloud.dnake.com)	112
European data center: (https://eu-cloud.dnake.com).....	113
Indian data center: (https://ind-cloud.ss-iot.com/login).....	115
SIP or landline supported countries and regions:.....	116

1. Introduction

1.1 Introduction

1. The DNAKE Cloud platform has 3 kinds of accounts: Distributor, Sub-distributor (optional) , Reseller/Installer, and Property Manager. Different users have unique functions on the platform. Here is the table for you to have a look at the distinctions.

















2. Reseller/Installer can also create sites and switch to sites to manage as a Property Manager.

3. One Property Manager can manage multiple sites.

No.	Distributor & Sub-distributor(optional)	Reseller /Installer	Property Manager
1	System Message	System Message	System Message
2	Personal Center	Personal Center	Personal Center
4	Reseller/Installer	Property Manager	Device (List)
5	/	Project	Apartment
6	/	Device (Management)	Resident (Resident & Access Control)
7	License Log	License Log	License Log
8	/	Update (Firmware List & Update List)	Security Alarm
9	My message	My message	My message
10	/	/	Log

1.2 Introduction of Some Icons

1. The icons you may see in the platform.

	Edit		Hide search
	Delete		Refresh
	Details		Synchronize All Residents data.
	Resend Email		Resident Details
	Device		Edit Value-added Services
	License Management		Renew
	Sync again		Set as Owner
	Replace Device		Introduction
	Access Device Webserver		

1.3 Supported Devices and Solutions

1. We are developing and adding more features to the platform and the DNAKE Smart Pro app. Some devices are supported now, while some will be supported in the near future. Please refer to the table below for the supported models:

(1) Door Station Without Indoor Monitor

- Requirements: The Door Station must be connected to the internet, registered on the SIP server, and added to the platform.
- Setup: Select "Without Indoor Monitor" license when creating an apartment (Without indoor monitor license will be used).

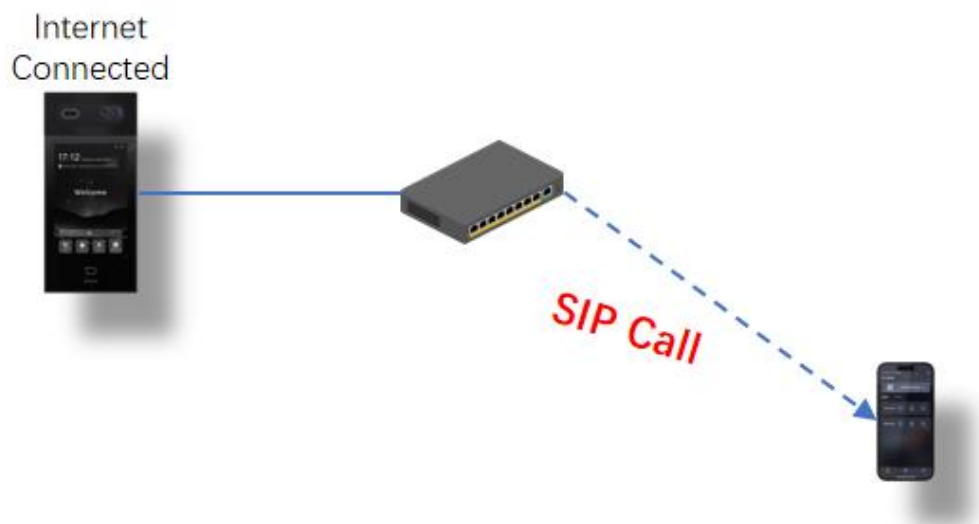

(2) Door Station With Indoor Monitor

- Requirements: The door station and indoor monitor should both be connected to the internet and added to the platform.
- Door Station should support being registered to the SIP server;
- Setup: Choose " With Indoor Monitor " license when creating an apartment (With indoor monitor license will be used).

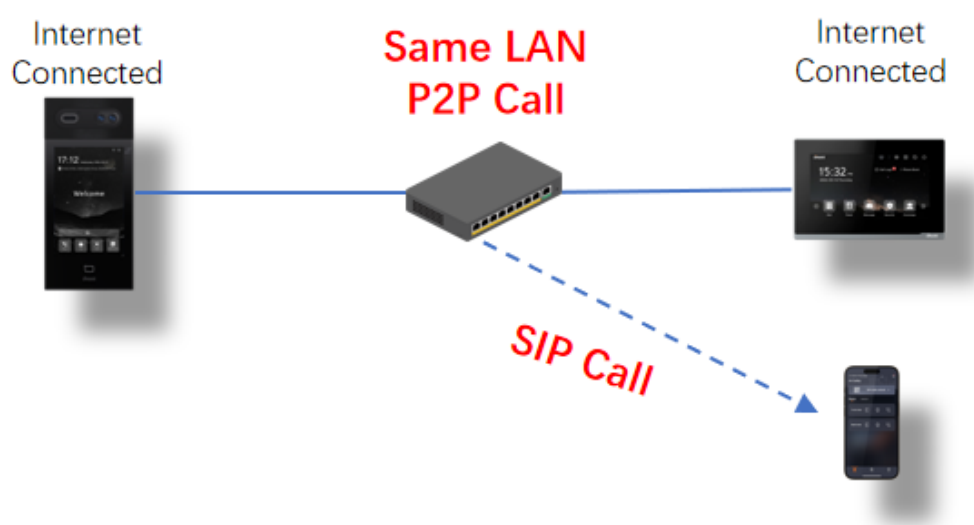

(3) No Door Station, but With Indoor Monitor

- Requirements: The indoor monitor should be connected to the internet and added to the platform.

- Setup: Select " With Indoor Monitor " license when creating an apartment (With indoor monitor license will be used).

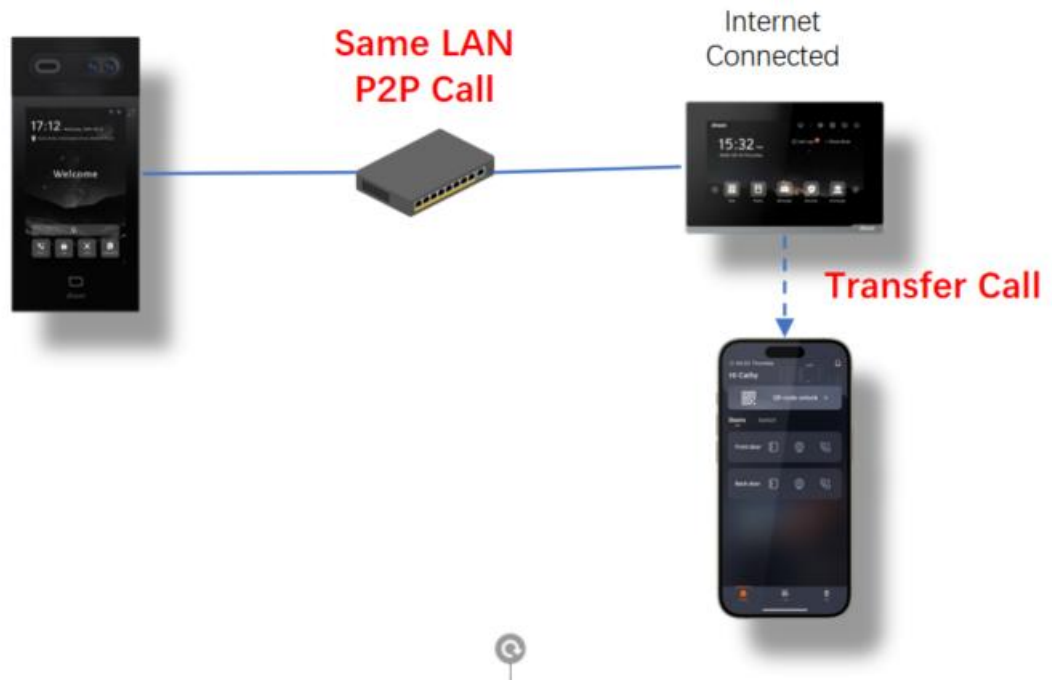

(4) Local Network Call (With Indoor Monitor)

- Requirements: This configuration operates without an internet connection, using a local network for P2P (peer-to-peer) calls.
- User Setup: No specific setup for SIP server registration is needed as the call is local.
- No Internet required.

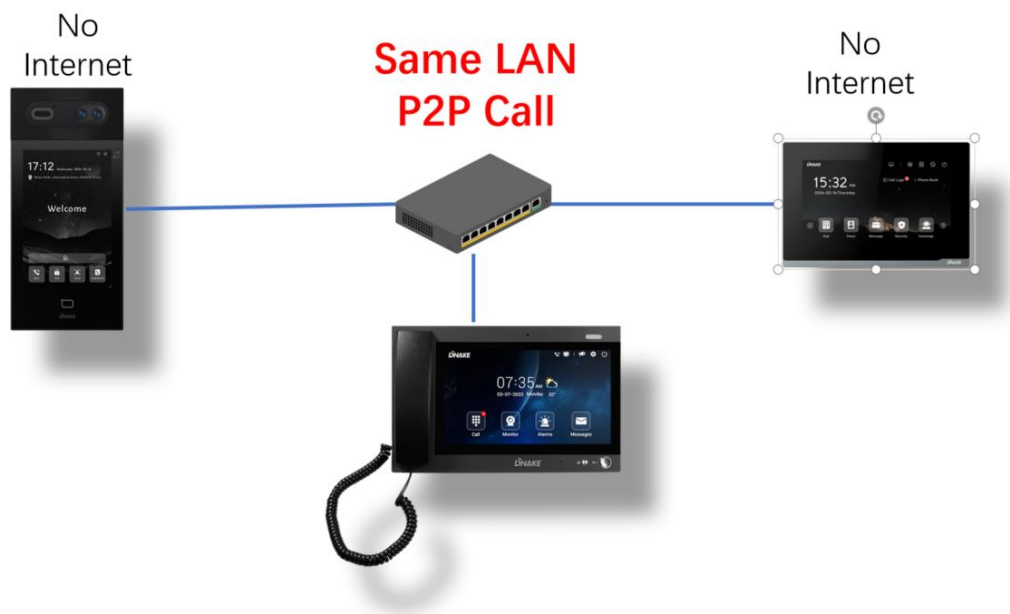

(5) Public Network Calling (With Indoor Monitor)

- Cloud Connectivity: The door station and indoor monitor connect to their designated network and register with the cloud.
- Seamless Communication: Once both devices are connected to the cloud, they can establish calls without the need to be in the same LAN environment.
- Flexibility: Devices can operate across different networks, providing greater deployment options.

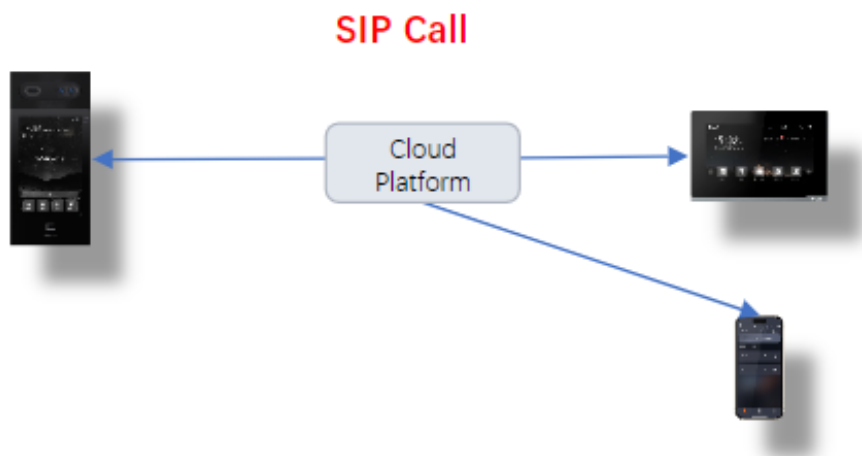

2. Support devices

Device type	Model
Door station (SIP Call)	C112
	S212
	S213K
	S213M
	S215
	S615
	S617
	S414
Indoor Monitor	E214
	E216
	E217
	A416
	E416
	H618
Master Station	902C-A
Access Control	AC01
	AC02
	AC02C
IP Kits	IPK06
	IPK07

	IPK08
TW Kits	TWK01
	TWK02
	TWK03
	TWK04
Elevator Control Module	EVC-ICC-A5

2. DNAKE provides different solutions.

- **With Indoor Monitor:**

Refers to the P2P solution with Indoor Monitor (Indoor Monitor must be installed for each household).

- **Without Indoor Monitor:**

Refers to the P2P or SIP solution without the Indoor Monitor. If you are among the SIP-supported countries and the device you use support SIP solution (e.g., S615 SIP updated with 904D_0_1_1_40_SIPV1_4_21_GA_20231123), the platform will choose the SIP solution automatically.

Please refer to **Appendix A: SIP or landline-supported countries and regions** for SIP-supported countries

- **Value-added Services:**

Refers to some premium services like SIP calls and landline features. This service is based on the Door Station Direct Call SIP solution.

Please note that value-added service can't be taken back if it's used.

- **Remote Management:**

Enables property managers to use the Smart Pro, ensuring they stay connected while on patrol. With this functionality, security personnel no longer need to worry about missing calls. This enhances communication and allows property managers to provide better services to residents.

2. Login and Logout

2.1 Login and Logout

2.1.1 Login

1. Log in to your account in a web browser

- ◆ Step 1: Provide your email and information to DNAKE or DNAKE partners to register an account. You will receive the account password in your email inbox.

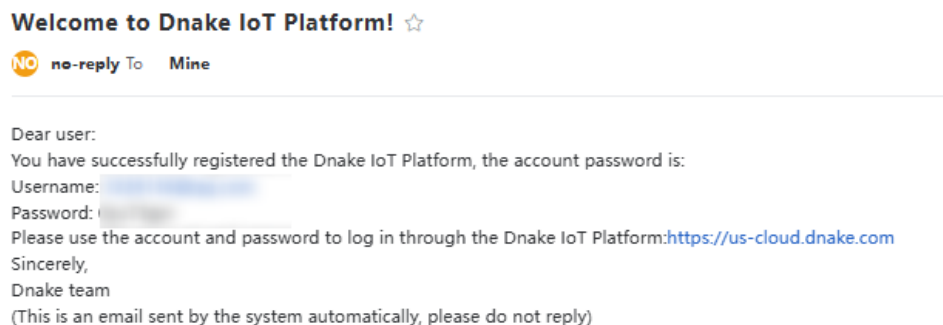

- ◆ Step 2: Please enter the platform website and log in with your account.

Different regions have different data centers. Please go to the URL according to the different regions.

European data center: <https://eu-cloud.dnake.com>.

American data center: <https://us-cloud.dnake.com>.

Indian data center: <https://ind-cloud.dnake.com>

Please refer to the appendix A for checking your country or region's data center.

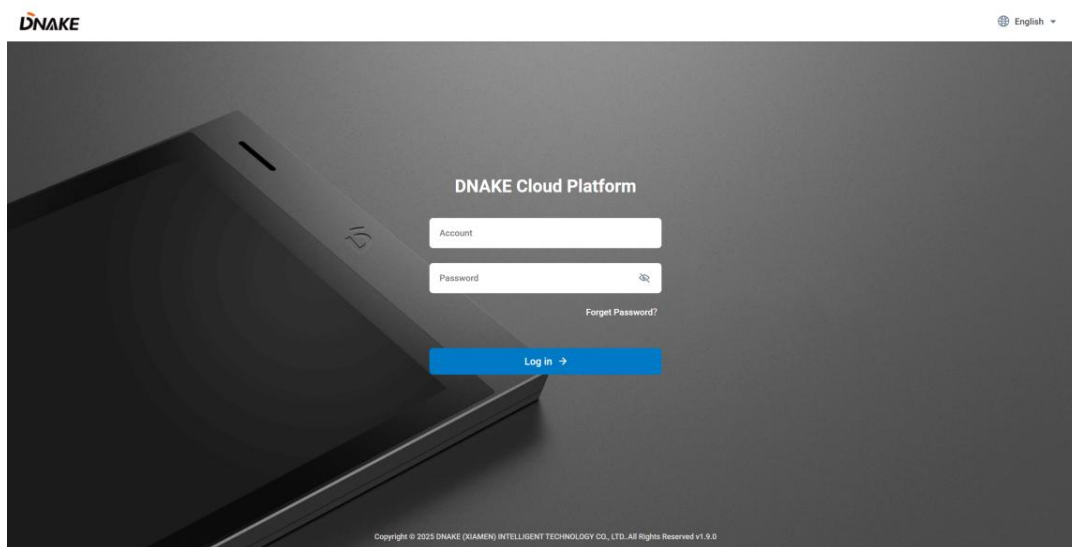

2.1.2 Logout

Click your personal account in the upper right-hand corner and log out.

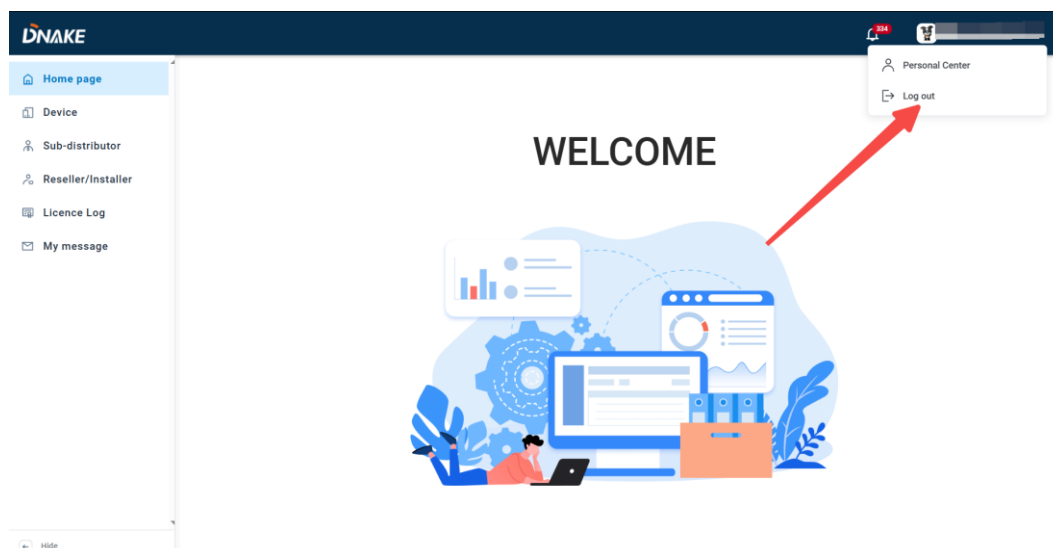

2.2 Forget password

1. Recover your password

- ◆ Step 1: Click Forget Password?

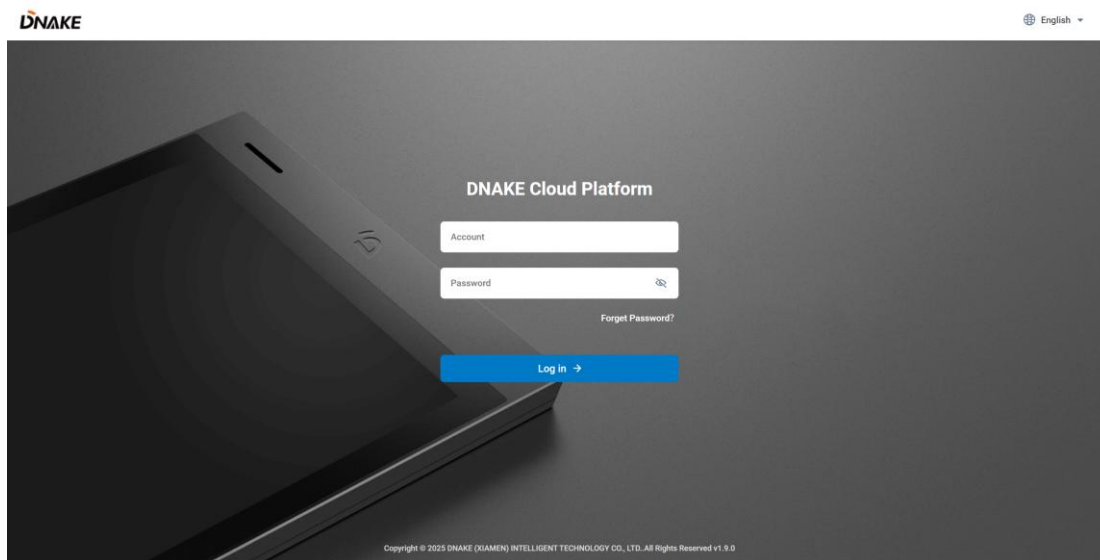

- ◆ Step 2: Enter your email and click Next.

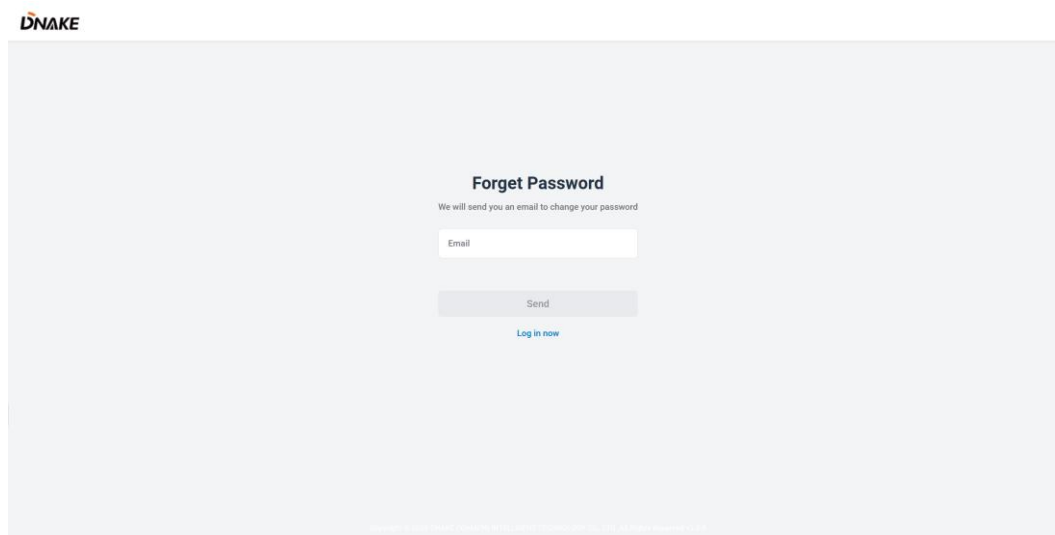

- ◆ Step 3: The platform will send you an email to change your password.

Please check your email inbox.

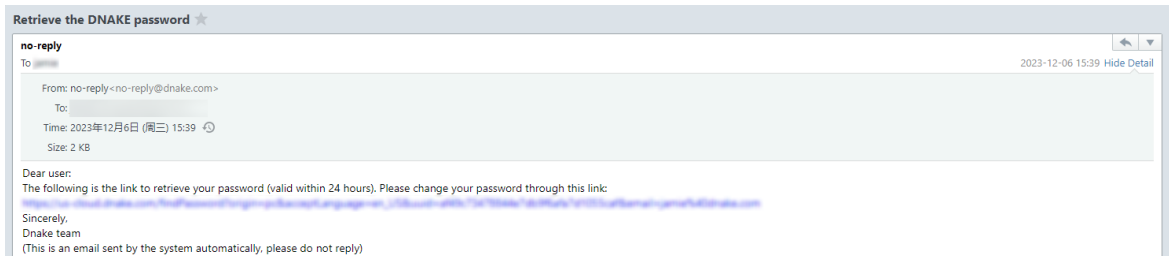
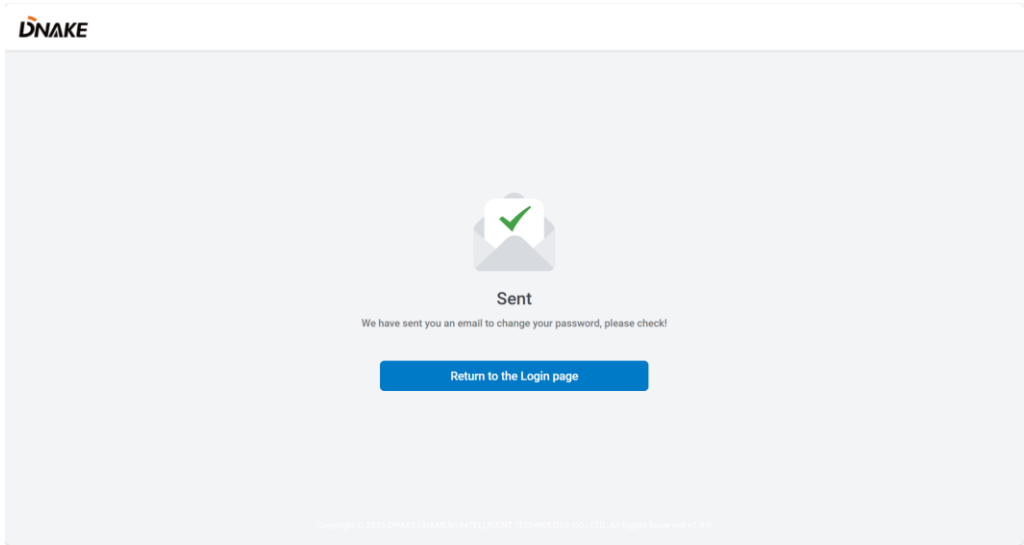

- ◆ Step 4: Please set a new password according to the rule and try to log in with the new password.

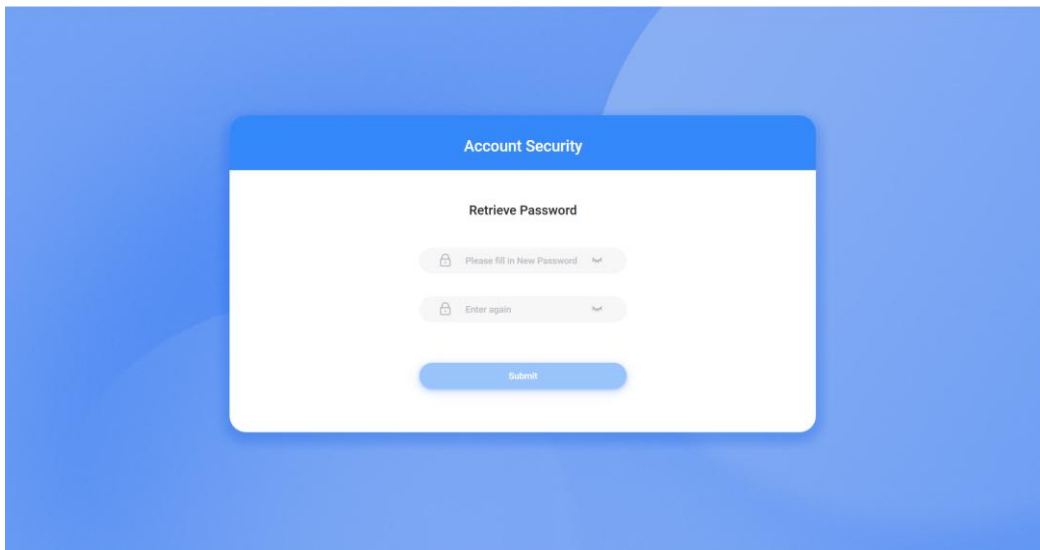

3. Personal Center and System Messages

3.1 Basic Information

1. You can check the details of the account you log in to. You can find your phone number, email address, role, project, creation time, or nickname, and so on. You can even change the profile photo.

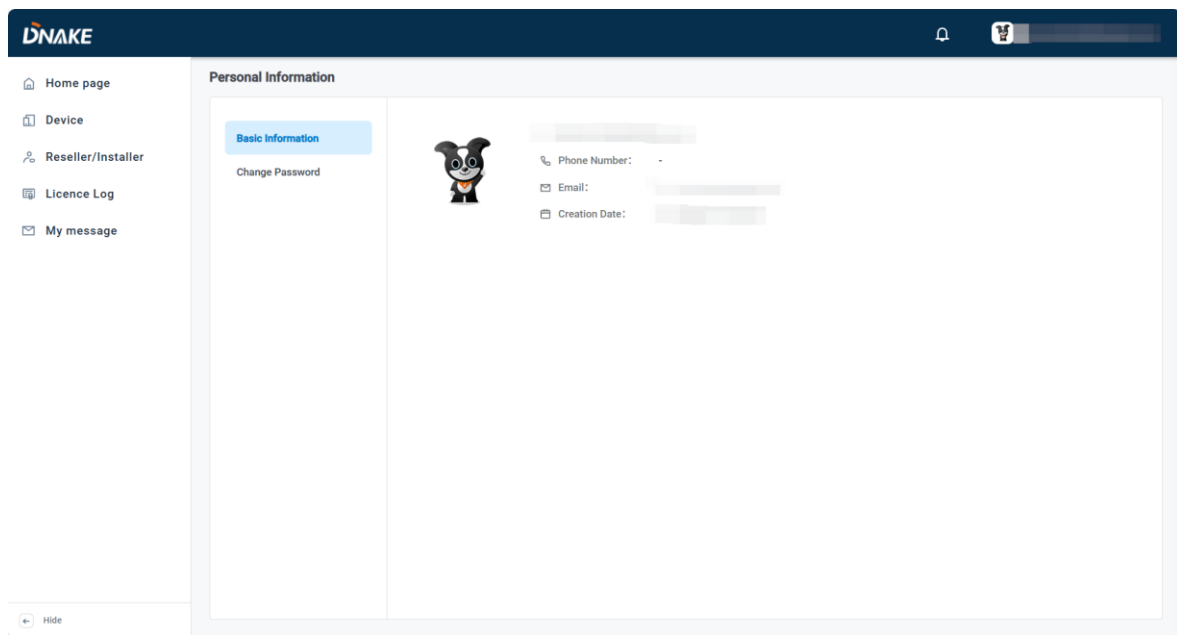

3.2 Change Password

1. If you want to change your password, please click Change Password to edit.

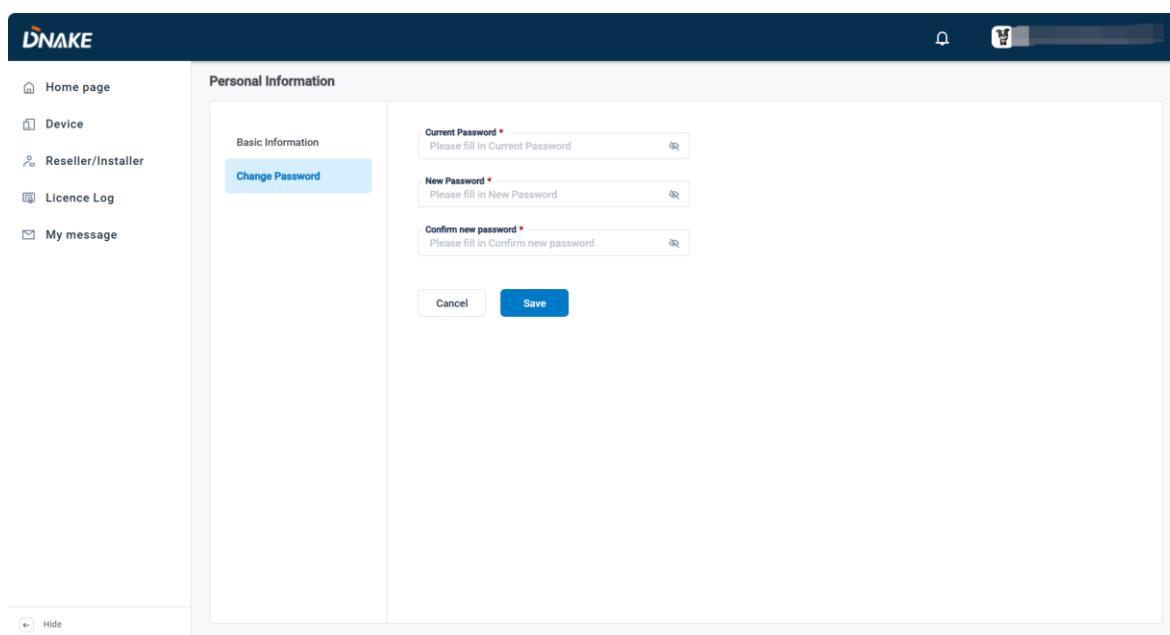

3.3 Login Settings

1. It is used to configure whether you need to fill in the verification code when you login the platform. It can help you to protect your account from being stolen. If it's enabled, the platform will send you a verification code to your email (the same as your account). After you click "Log in" on the login page, you should fill in the correct code before logging in. If it's disabled, you will log in directly after you click "Log in".

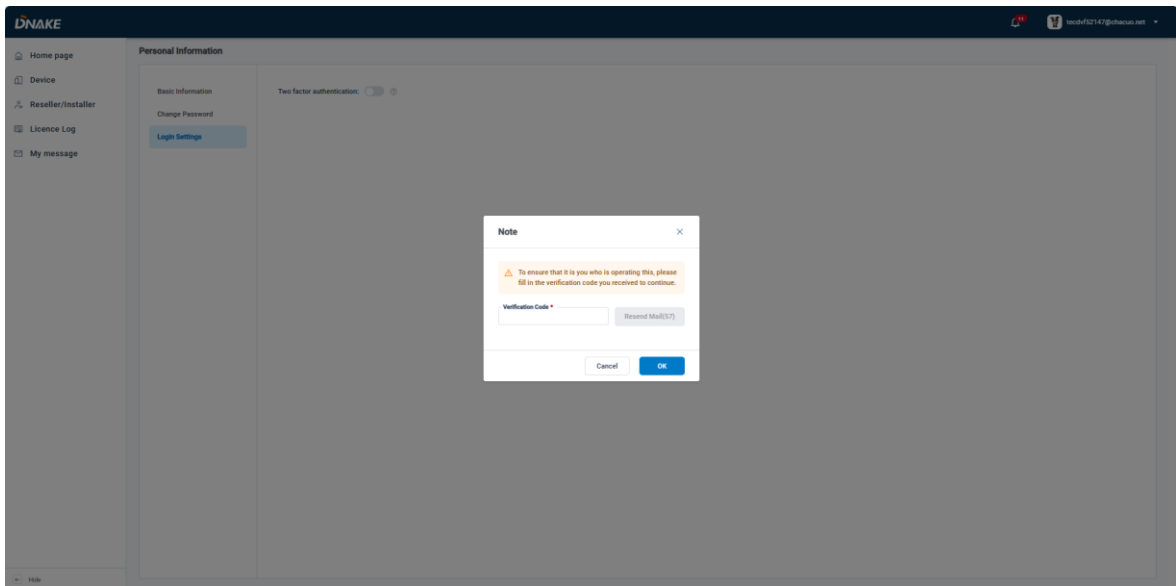
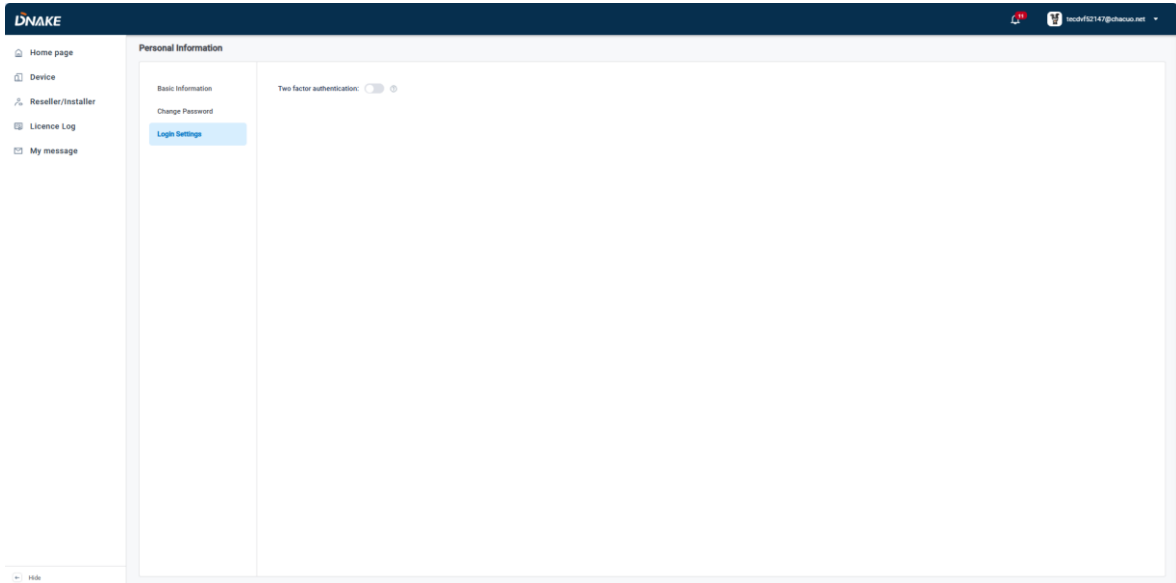

3.4 System Message

1. System message comes from your upstream characters. For example, if you are a reseller, you will receive messages from distributors/sub- distributor and you can also send messages to your downstream customers.

DNAKE 🔔 👤

- 🏠 Home page
- 📄 Device
- 👤 Reseller/Installer
- 📅 Licence Log
- ✉️ My message

System Message

The quantity of your license has been chan... 2025-06-17 14:20:01	
The quantity of your license has been chan... 2025-03-19 17:05:59	
~ End ~	

Hide

4. Distributor

4.1 Manage the device

- ◆ Distributors can now access the Device menu to view devices added by their associated resellers or installers. This feature provides visibility into device distribution while maintaining hierarchical management.

The **Device** menu includes the following details:

- **Site:** The site associated with the device.
- **Reseller/Installer:** The reseller or installer who imported the device.
- **Device Name**
- **Type**
- **Model**
- **Status**
- **MAC Address**

Item	Site	Ascription	Reseller/Installer	Device Name	Type	Model	Status	MAC
1							Offline	
2							Online	
3							Online	
4							Online	

4.2 Sub-Distributor

A Distributor can create up to 4 Sub-Distributor accounts. Sub-Distributors inherit the same permissions and system access rights as the Distributor.

4.2.1 Add Sub-Distributor Account

How to Create a Sub-Distributor

- ◆ Step 1: Go to the Sub-Distributor column and click the Add Sub-Distributor button in the upper-right corner.

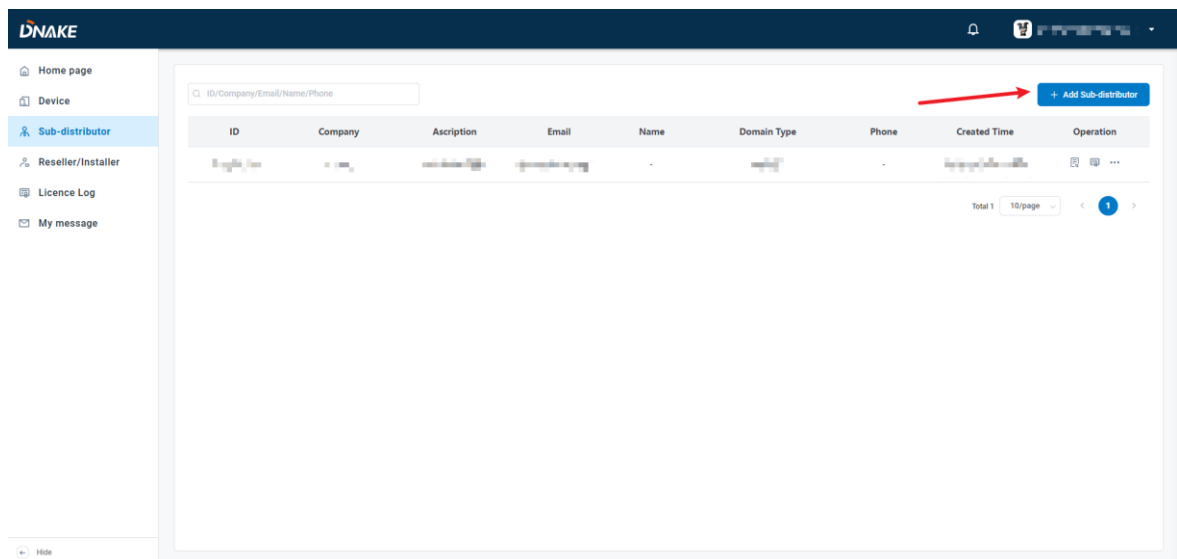

- ◆ Step 2: Fill in Sub-Distributor information. The Company, Email, and Language fields are required. You can also enable or disable the permission that allows the Sub-Distributor to create additional Sub-Distributor accounts. Please make sure the email is right because the email will be the reseller/installer’s account. And the password will be sent to this email address.

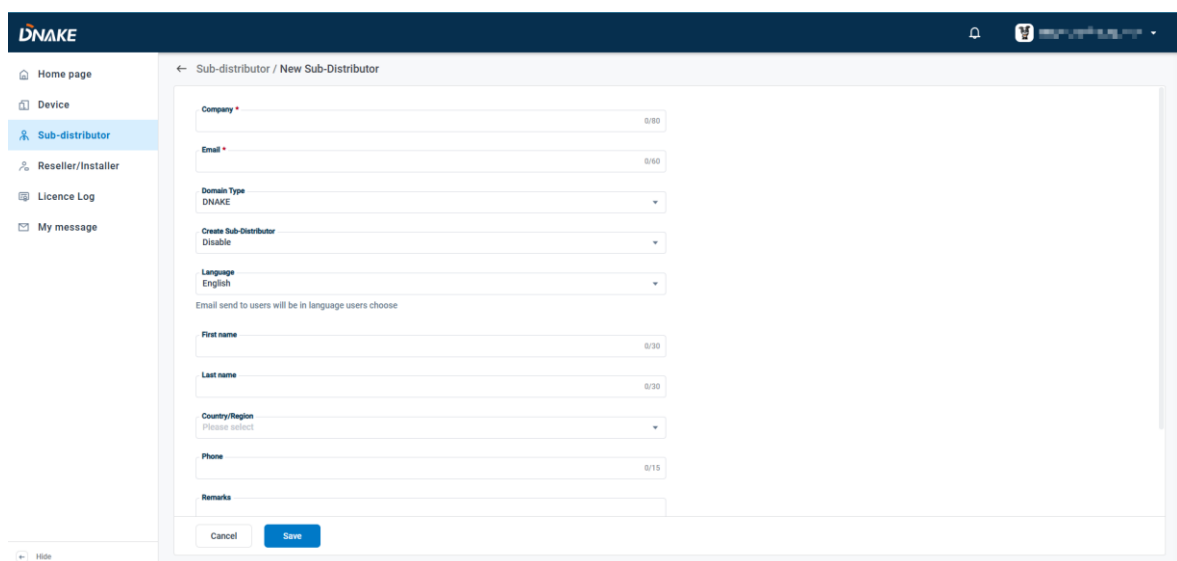

4.2.2 Manage Sub-Distributor Account

1. After creating a Sub-Distributor, you can click Details to view the detailed information of the Sub-Distributor.

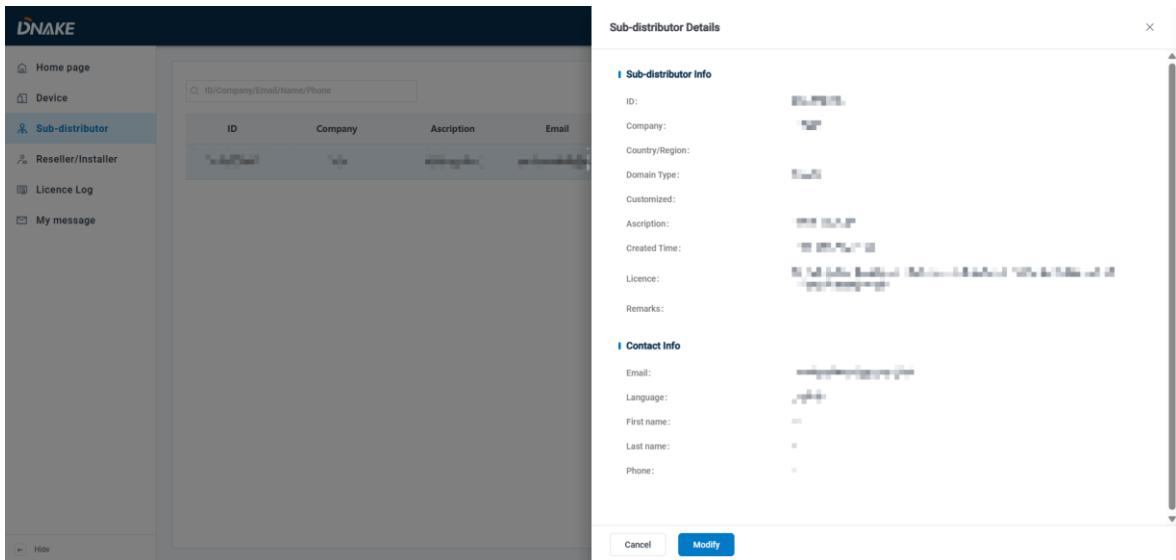
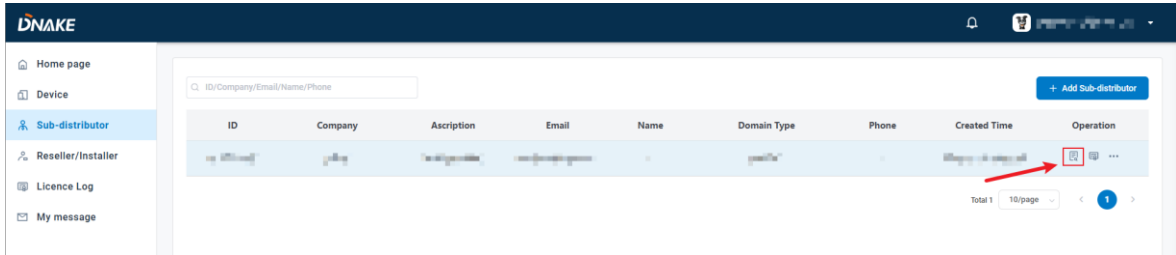

2. You can also click License Management to manage the licenses of the Sub-Distributors. As a Distributor, you are allowed to increase or reduce the amounts of different types of services for a Sub-Distributor.

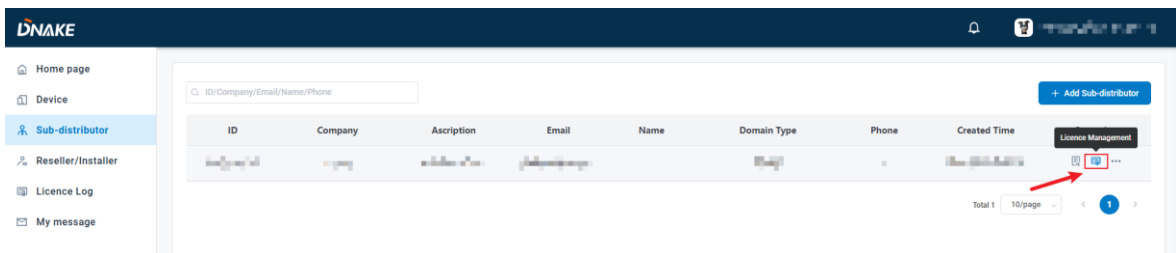

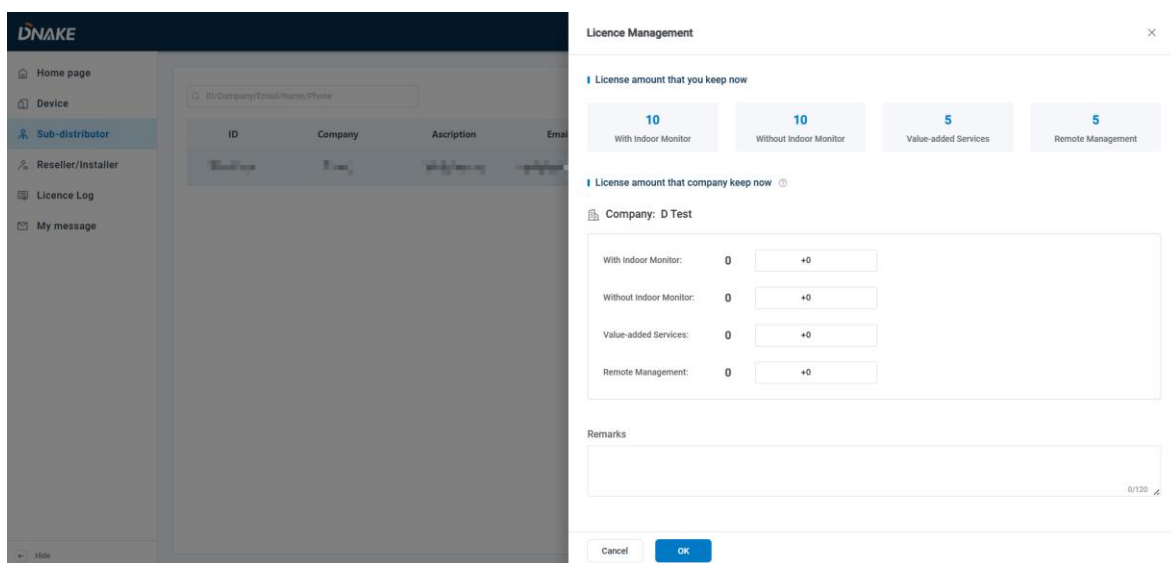

3. Finally, you can click the menu button to edit the Sub-Distributor information, resend the registration email, or delete the Sub-Distributor account.

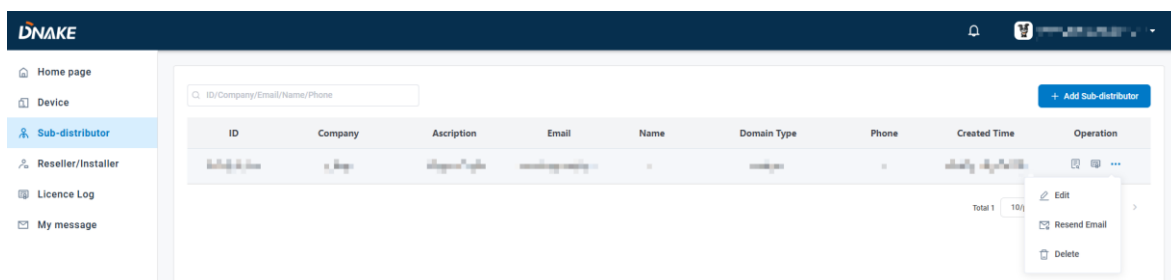

4.2.3 License Management

1. The license is necessary for the residents to use the app. Every DNAKE Smart Pro app host user needs one license to have the app service. You can find different types of services:

- **With Indoor Monitor:**

Refers to the P2P solution with Indoor Monitor (Indoor Monitor must be installed for each household).

- **Without Indoor Monitor:**

Refers to the P2P or SIP solution without the Indoor Monitor. If you are among the SIP-supported countries and the device you use support SIP solution, the platform will choose SIP solution automatically.

Please refer to **Appendix A: SIP or landline supported countries and regions** for SIP-supported countries

- **Value-added Services:**

Refers to some premium services like SIP call and landline feature. This service is based on Door Station Direct Call SIP solution.

Please note that value-added service can't be taken back if it's used.

- **Remote Management:**

Enables property managers to use the Smart Pro, ensuring they stay connected while on patrol. With this functionality, security personnel no longer need to worry about missing calls. This enhances communication and allows property managers to provide better services to residents.

4.3 Reseller/Installer

4.3.1 Add a Reseller/Installer Account

1. Here are the steps to add a reseller/installer account

- ◆ Step 1: Go to the Reseller/installer column and click Add to add a reseller/installer account.

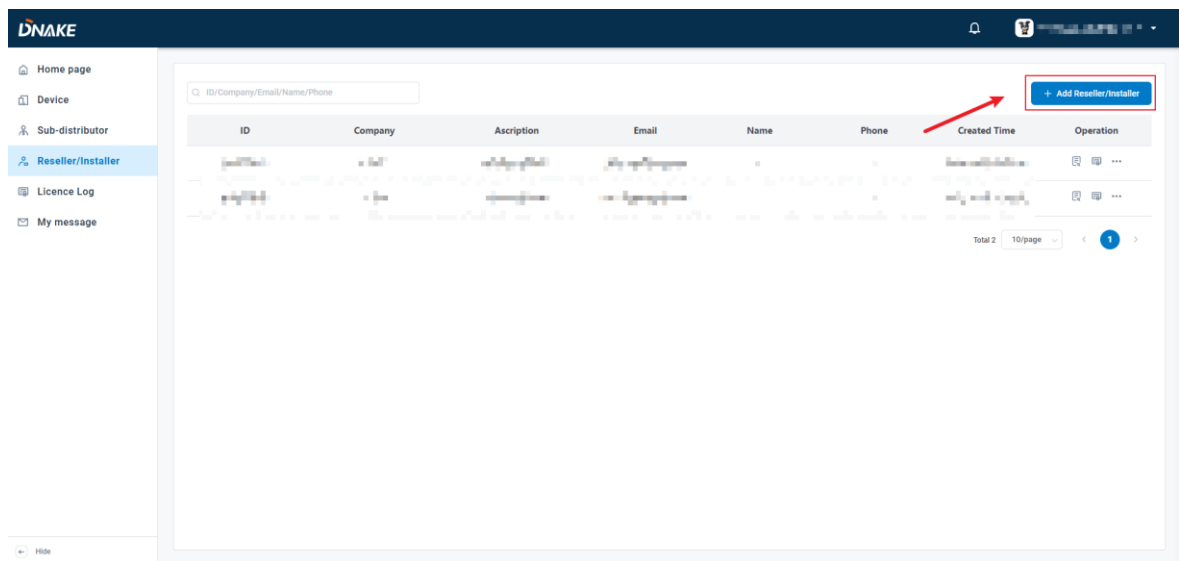

- ◆ Step 2: Fill in reseller/installer’s information. Company name, Email and language are necessary. Please make sure the email is right because the email will be the reseller/installer’s account. And the password will be sent to this email address.

← Reseller/Installer / New Reseller/Installer

Company *

Email *

Language
English

Email send to users will be in language users choose

First name

Last name

Country/Region
Please select

Phone

Remarks

Cancel Save

4.3.2 Manage Reseller/Installer Account

1. After creating a Reseller/Installer account, you can click Details to view the detailed information of the Reseller/Installer.

Q: ID/Company/Email/Name/Phone

+ Add Reseller/Installer

ID	Company	Ascription	Email	Name	Phone	Created Time	Details	Action
[blurred]	[blurred]	[blurred]	[blurred]	[blurred]	[blurred]	[blurred]	[blurred]	[blurred]
[blurred]	[blurred]	[blurred]	[blurred]	[blurred]	[blurred]	[blurred]	[blurred]	[blurred]

Total 2 10/page 1

Reseller/Installer Details

Reseller/Installer Info

ID: [blurred]

Company: [blurred]

Country/Region: [blurred]

Ascription: [blurred]

Created Time: [blurred]

Licence: [blurred]

Remarks: [blurred]

Contact Info

Email: [blurred]

Language: [blurred]

First name: [blurred]

Last name: [blurred]

Phone: [blurred]

Cancel Modify

2. You can also click License Management to manage the licenses of the Reseller/Installer. As a Distributor, you are allowed to increase or reduce the amounts of different types of services for the Reseller/Installer.

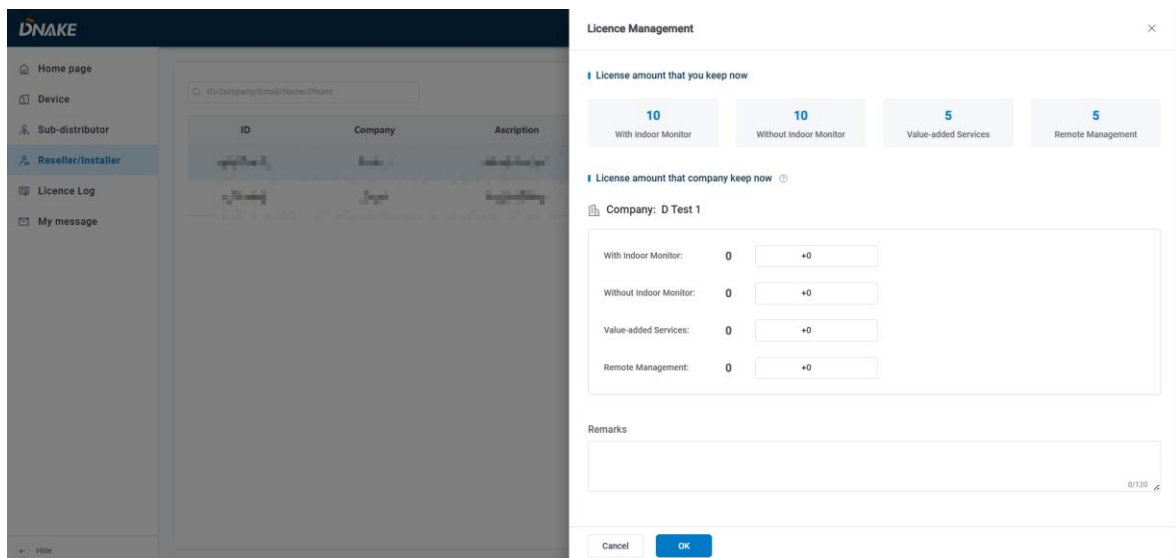
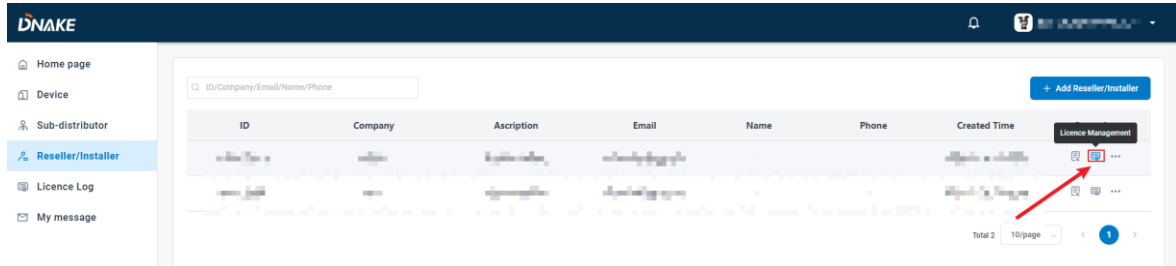

3. Finally, you can click the menu button to edit the Sub-Distributor information, resend the registration email, or delete the Sub-Distributor account.

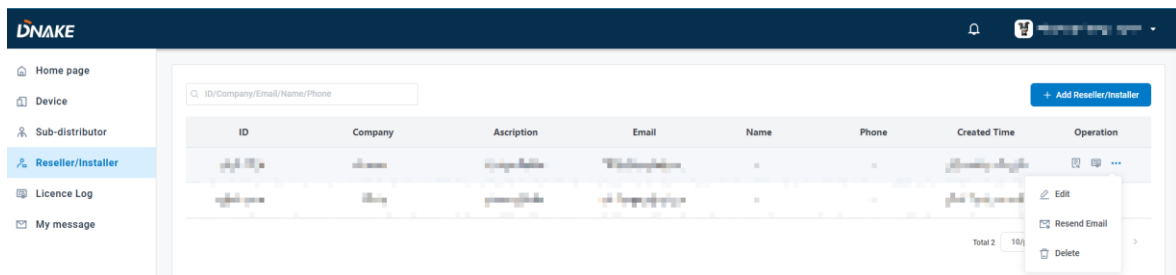

4.3.3 License Management

1. The license is necessary for the residents to use the app. Every DNAKE Smart Pro app host user needs one license to have the app service. You can find different types of services:

- **With Indoor Monitor:**

Refers to the P2P solution with Indoor Monitor (Indoor Monitor must be installed for each household).

- **Without Indoor Monitor:**

Refers to the P2P or SIP solution without the Indoor Monitor. If you are among the SIP-supported countries and the device you use support SIP solution, the platform will choose the SIP solution automatically.

Please refer to **Appendix A: SIP or landline-supported countries and regions** for SIP-supported countries

- **Value-added Services:**

Refers to some premium services like SIP calls and landline features. This service is based on the Door Station Direct Call SIP solution.

Please note that value-added service can't be taken back if it's used.

- **Remote Management:**

Enables property managers to use the Smart Pro, ensuring they stay

connected while on patrol. With this functionality, security personnel no longer need to worry about missing calls. This enhances communication and allows property managers to provide better services to residents.

As a distributor, you are allowed to increase or reduce the amounts of different types of services for reseller/installer.

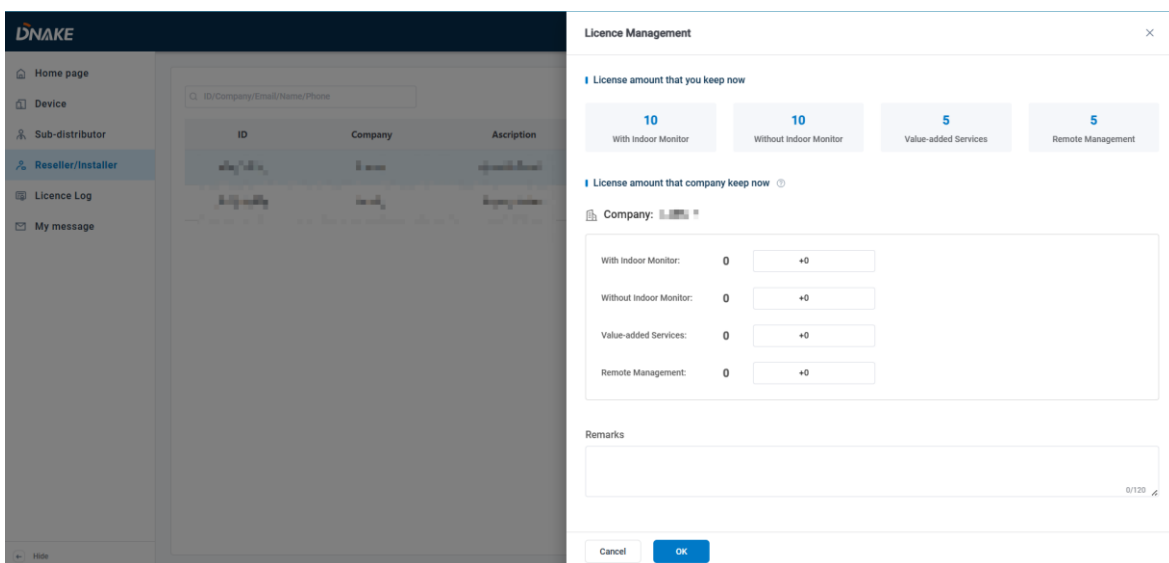

4.4 License Log

1. You can check the number of licenses you have and the license log.

Item	Time	Type	Operation	Amount	Source/Destination	Holdings	Remarks
1	2026-03-13 13:59:58	Remote Management	Issued By Superior	+ 5		5	-
2	2026-03-13 13:59:58	Value-added Services	Issued By Superior	+ 5		5	-
3	2026-03-13 13:59:58	With Indoor Monitor	Issued By Superior	+ 10		10	-
4	2026-03-13 13:59:58	Without Indoor Monitor	Issued By Superior	+ 10		10	-

4.5 My message

4.5.1 Send Messages to Reseller/Installer

1. Here are the steps to send messages to the reseller/installer

- ◆ Step 1: Go to the My message column and click Add to edit a message.

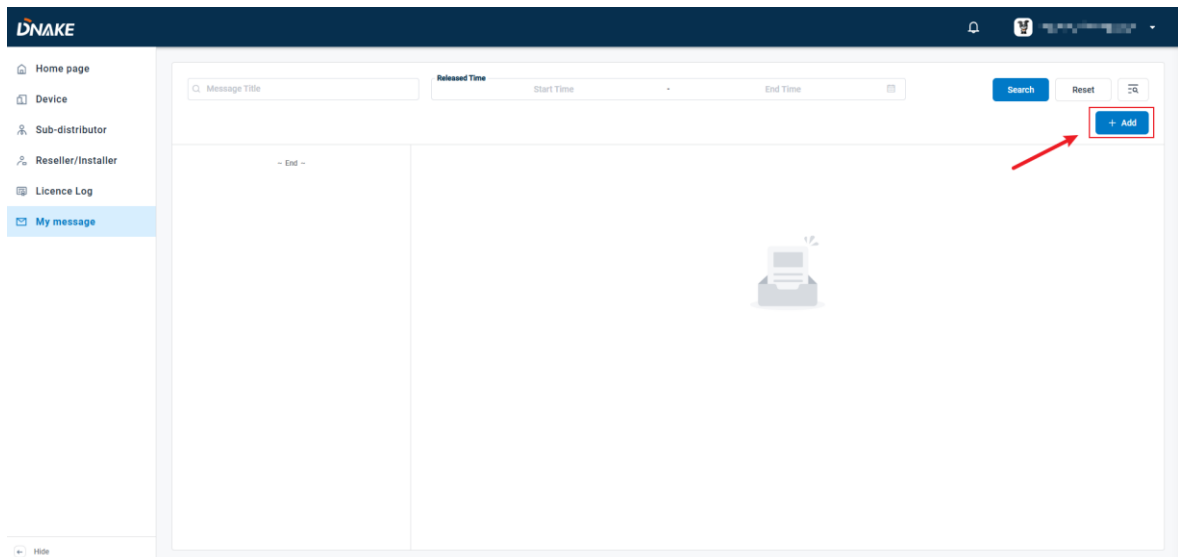

- ◆ Step 2: Fill in the message title and message content. Choose the recipient and the delivery time.

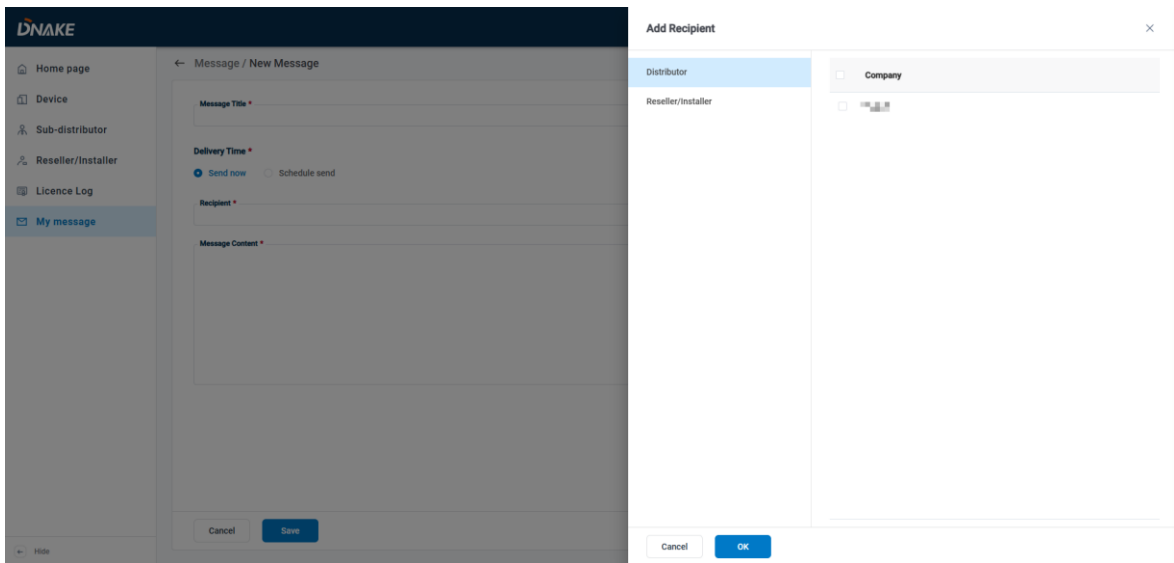

◆ Step 3: Click the message. You can check the message details.

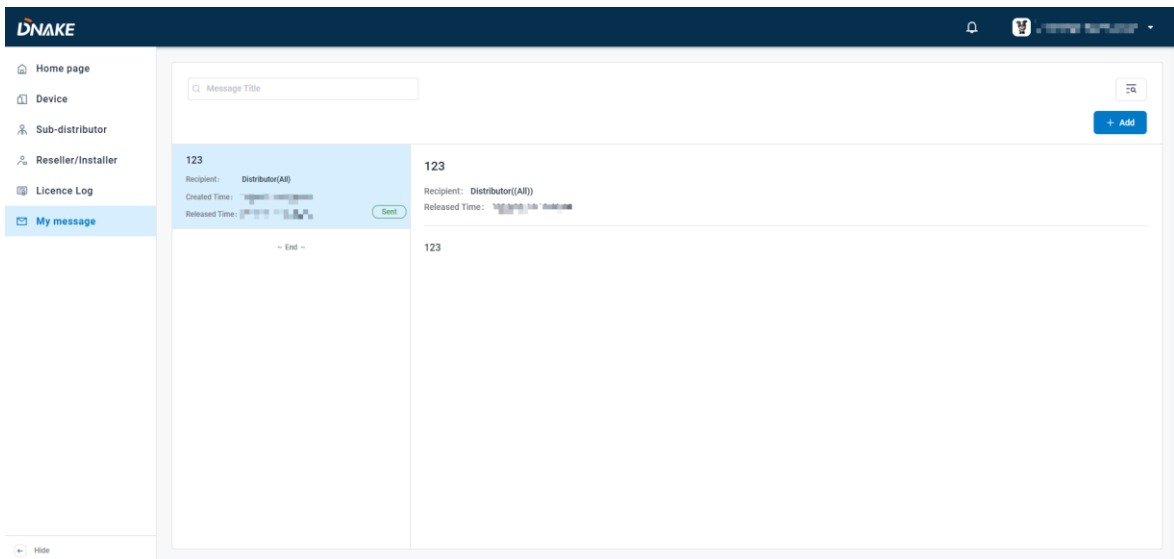

5. Reseller/Installer

5.1 Home page

- Here is the dashboard for tracking the number of sites and devices. Also, the quick operation to create a new community, a new single-family home, etc.

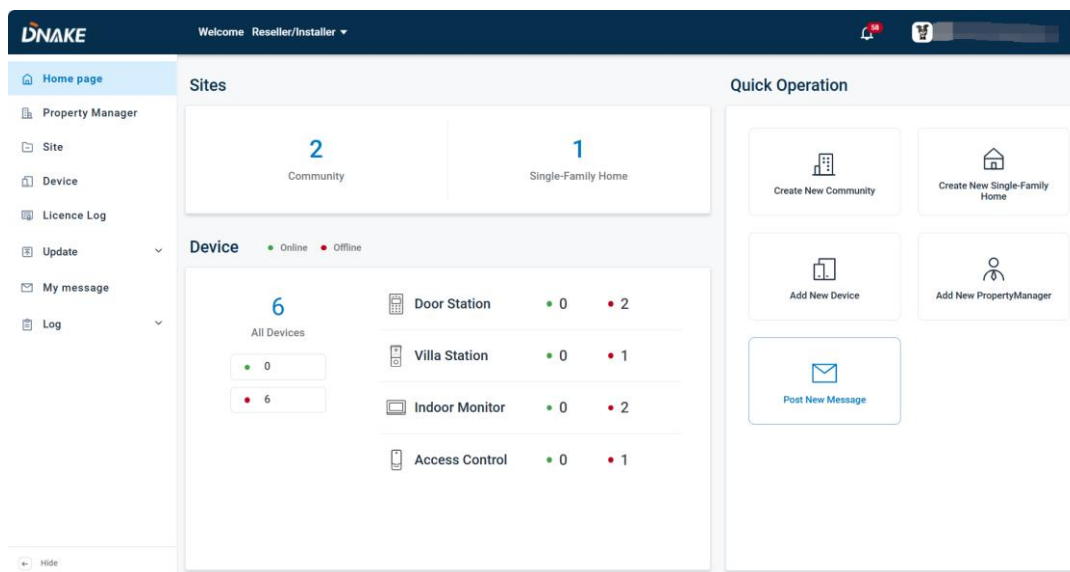

5.2 Property Manager

5.2.1 Add a Property Manager Account

- Here are the steps to add a property manager account

- ◆ Step 1: Go to the Property Manager column and click Add to add a property manager account.

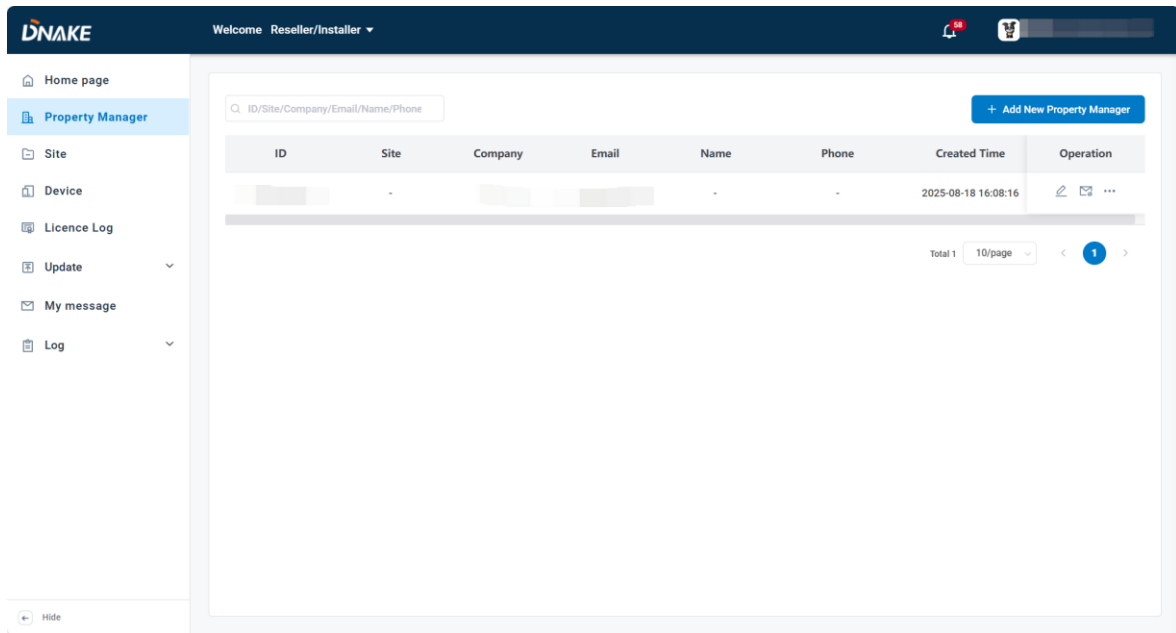

- ◆ Step 2: Fill in the property manager's information. Company name, Email and language are necessary. Please make sure the email is right because the email will be the property manager's account. And the password will be sent to this email address.

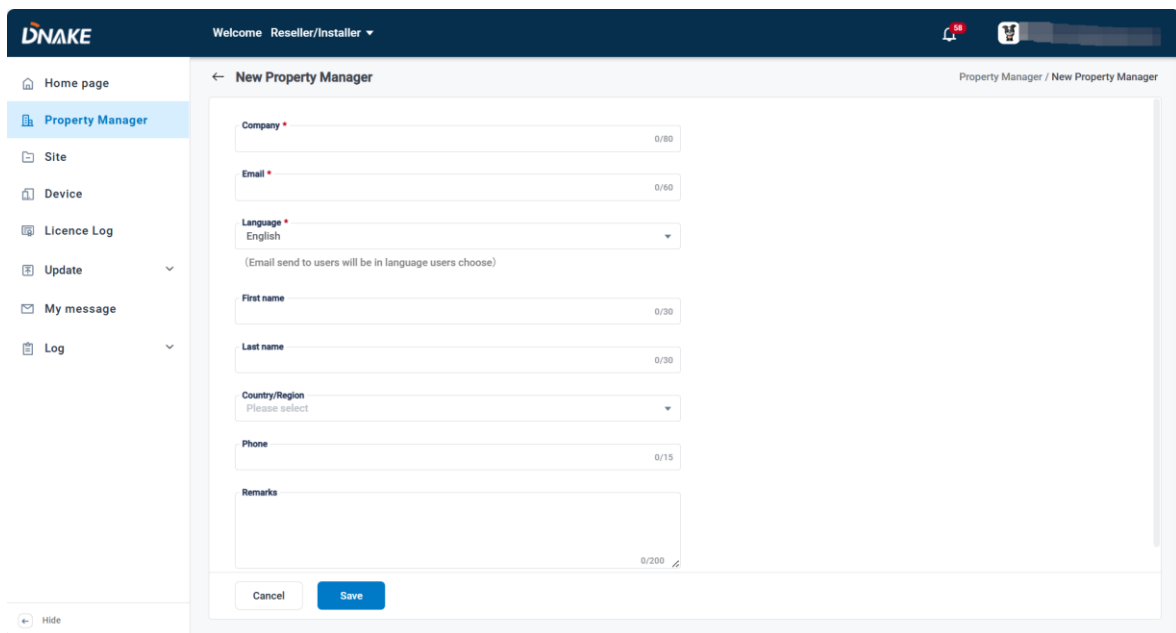

5.2.2 Manage Property Manager Account

1. After registering a property manager account, you can edit, delete, check it, and resend the registration email.

ID	Site	Company	Email	Name	Phone	Created Time	Operation
PM67922667	-	Tech	123@gmail.com	-	-	2025-08-18 16:08:16	<ul style="list-style-type: none"> Details Delete

5.3 Site

5.3.1 Add a Community

1. Here are the steps to add a community

- ◆ Step 1: Go to the Site column and click New Community to add a new community.

Name	Site ID	Property Manager	Created Time	Operation
[Redacted]	[Redacted]	[Redacted]	2025-08-12 10:19:20	[Icons]
[Redacted]	[Redacted]	[Redacted]	2025-07-14 09:29:35	[Icons]

- ◆ Step 2: Fill in community information. Community name and Country/Region are necessary.

Allow Residents Register Face:

It is the face recognition function. If you have a Door Station with a face recognition function, you can enable it for app users to upload their face data via the app.

Remote management:

It is used to configure whether the property manager is allowed to manage Villa Station as an access control device. If enabled, the property manager will see the device when creating access control. If disabled, the property manager will not have permission to create access control for Villa Station.

Sync Resident to Phonebook by default:

It's used to configure whether "Sync to Phonebook on device" is enabled on the resident setting page of this site. If enabled, "Sync to Phonebook on device" will be enabled by default. Otherwise, it will be disabled by default.

Report Device Anomalies:

It is used to configure whether to send a report to the administrator when an abnormality occurs on the device.

Community name * 0/30
Country/Region *
 Please select
Property Manager
 Please select
Email 0/60
Phone 0/15
Building structure
 Building/Unit/Apartment
Resident Permissions
 Register Face ID in the APP Register Account in the APP
Access Control Permission
 Config Private Devices on the Platform ⓘ
Remote Management
 ⓘ
Daylight saving time

Sync Resident to phonebook by default
 ⓘ
Report Device Anomalies
 ⓘ
Remarks

5.3.2 Manage Community

1. After creating a community, you can edit, delete, check it, and auto deploy log, or click the Site Management icon or the name of the community to jump to the Site Management page to manage devices, apartments, and residents of this community.

Community Single-Family

Q Site ID/Name/Property Manag

+ New Community

Name	Site ID	Property Manager	Created Time	Operation
Demo_Case_Community	0101829612	Dnake (fvmax111@gmail.com)	2025-08-12 10:19:20	📄 📄 ⋮
Dnake	0101134547	Dnake (fvmax111@gmail.com)	2025-07-14 09:29:3	✏ Edit 📄 Auto Deploy Log 📄 Details 🗑 Delete

Total 2 10 >

5.3.3 License Management

1. The license is necessary for the residents to use the app. Every DNAKE Smart Pro app host user needs one license to have the app service. You can find different types of services:

- **With Indoor Monitor:**

Refers to the P2P solution with Indoor Monitor (Indoor Monitor must be installed for each household).

- **Without Indoor Monitor:**

Refers to the P2P or SIP solution without the Indoor Monitor. If you are among the SIP-supported countries and the device you use support SIP solution, the platform will choose the SIP solution automatically.

Please refer to **Appendix A: SIP or landline-supported countries and regions** for SIP-supported countries.

- **Value-Added Services:**

Refers to some premium services like SIP calls and landline features. This service is based on the Door Station Direct Call SIP solution.

Please note that value-added service can't be taken back if it's used.

As a reseller/installer, you are allowed to increase or reduce the amounts of different types of services for sites.

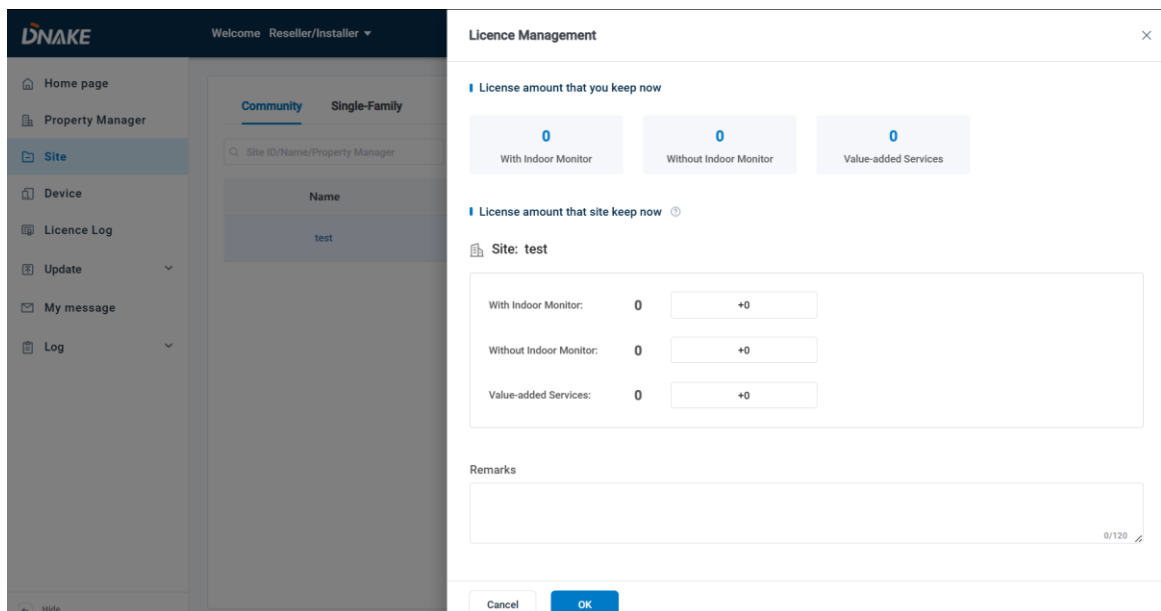

5.3.4 Device and Resident Management

Within the left - side Community classification module, users can add "New Building" to enter basic information of newly added buildings and "Public Areas" to manage shared space information, including the main entrance, laundry room, delivery room, and parking lot.

1. Here are the steps to create a community

- ◆ Step 1: Click New Public Area to create a new public area or directly rename the existing public area. Then click the Public Area you've created to manage the devices inside.

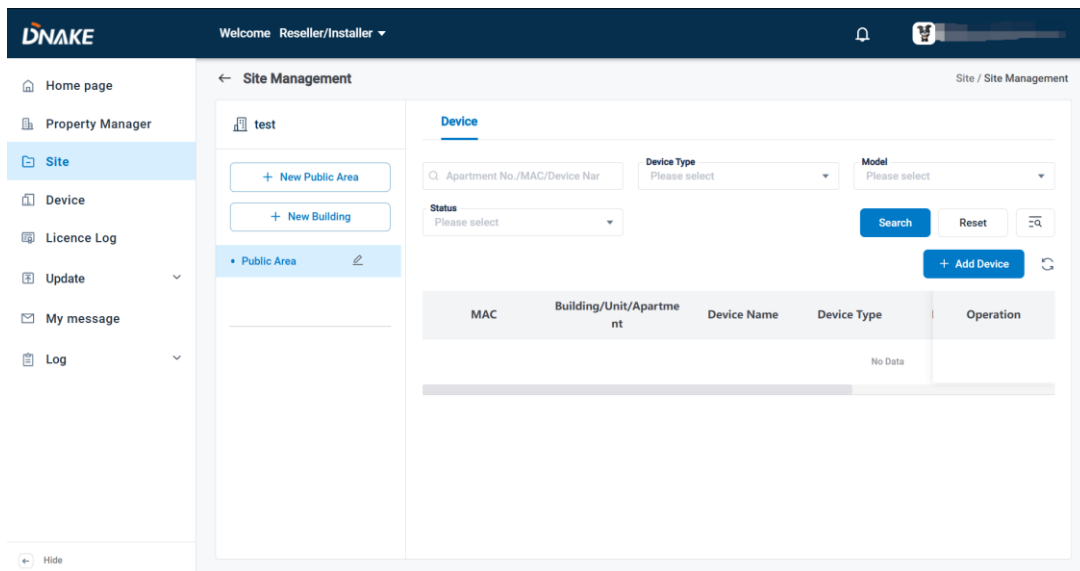

- ◆ Step 2: Click Add Device, then select or fill in the device's basic information like device type, MAC address, and device name, etc. Then click save to finish it.

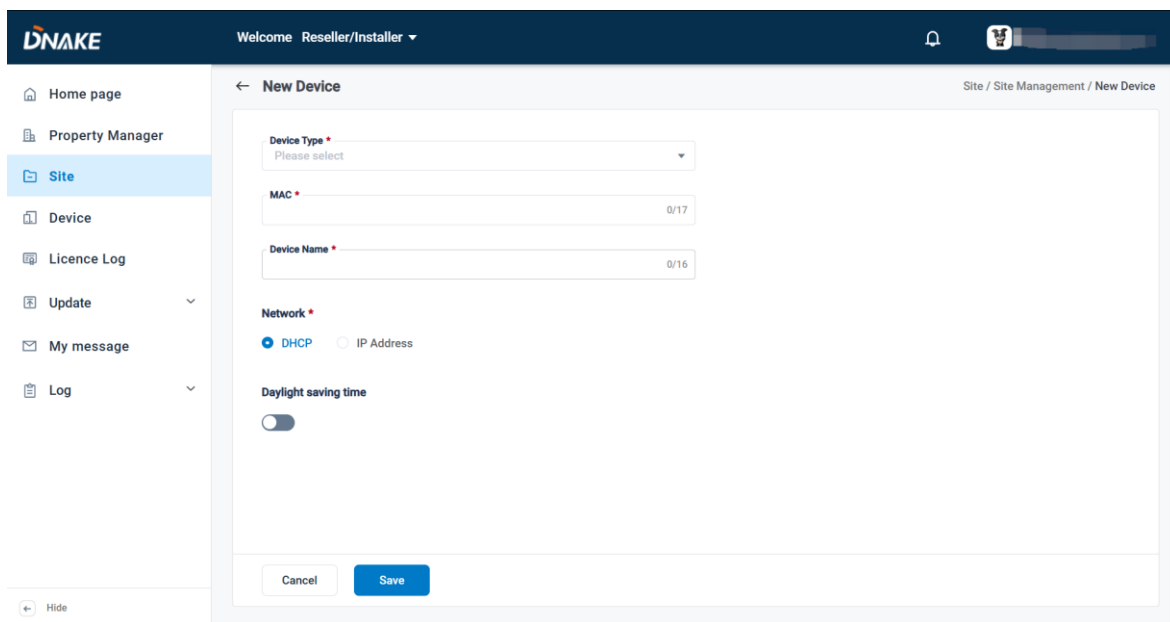

- ◆ Step 3: Go back to the site management page and click New building to add a new building. Then select the building number and fill in the building name.

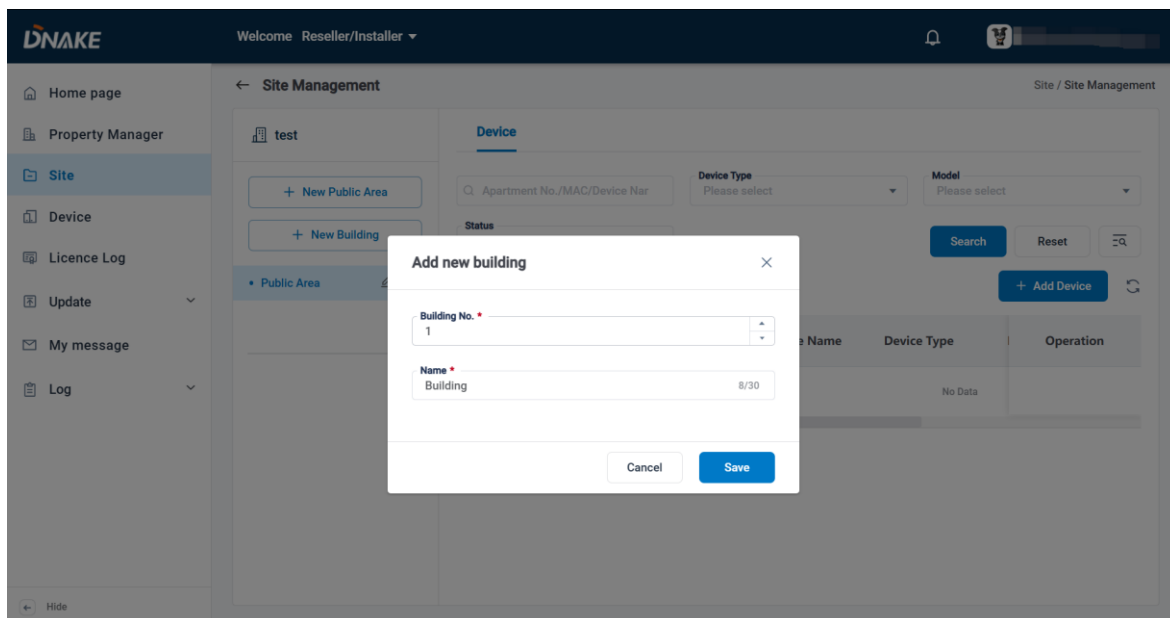

- ◆ Step 4: Click the building you've created and click Add Apartment to add a new apartment. Apartment number and license selection are necessary when creating a new apartment.
- ◆ Step 5: You can select to add a new resident on the same page.

The screenshot displays the DNAKE Site Management interface. On the left is a navigation menu with options: Home page, Property Manager, Site (highlighted), Device, Licence Log, Update, My message, and Log. The main content area is titled 'Site Management' and shows a 'test' site. It includes buttons for '+ New Public Area' and '+ New Building'. Below these is a list of public areas, with '1 - Building' selected and highlighted. A red arrow points to this entry. To the right, there are tabs for 'Apartment', 'Device', and 'Resident'. Under the 'Apartment' tab, there are input fields for 'Apartment No.' and 'Call Type', a 'Search' button, a 'Reset' button, and a '+ Add Apartment' button. A red arrow points to the '+ Add Apartment' button. Below this is a table with columns: Building/Unit/Apartment, Call Type, Resident, and Operation. The table is currently empty, showing 'No Data'. Below the table is a 'New Apartment' form with fields for 'Building No.' (filled with '1 - Building'), 'Unit No.', 'Apartment No.', and 'License Selection' (a dropdown menu with 'Please select'). A link below the form reads 'Add the resident (householder) to this apartment by the way'. A red arrow points to this link. At the bottom of the form are 'Cancel' and 'Save' buttons.

Noted: Without an Indoor Monitor license, it must be selected when there is no indoor monitor online on the cloud, and that **With Indoor Monitor** license, it should be chosen when there is an indoor monitor available. For scenarios involving no calls, such as learning or testing

purposes, **"Not use"** can be selected. Once a license **with** or **without an indoor monitor** is selected, the choice cannot be modified. If modification is required, the original apartment (apt) must be deleted and re-added. However, deleting the apartment will result in the removal of all residents within the corresponding room.

- ◆ Step 6: Click Device, then Add Device to add a new device.

The screenshot displays the 'Site Management' interface. On the left, there is a sidebar with a 'test' header and buttons for '+ New Public Area' and '+ New Building'. Below these are sections for 'Public Area' and '1 - Building'. The main content area has three tabs: 'Apartment', 'Device' (which is selected and underlined), and 'Resident'. Under the 'Device' tab, there are search filters for 'Apartment No./AC/Device Name', 'Unit No.', 'Device Type', 'Model', and 'Status'. There are 'Search', 'Reset', and '+ Add Device' buttons. Below the filters is a table with columns: 'Building/Unit/Apartment', 'Device Name', 'Device Type', 'Model', 'Status', and 'Operation'. The table currently shows 'No Data'. Two red arrows point to the 'Device' tab and the '+ Add Device' button.

←
New Device

Device Type *

Door Station

MAC *

0/17

Building No. *

1 - Building

Unit No.

Please select

Device No. *

1

▲
▼

Integer between 1-99

Device Name *

0/16

Network *

DHCP
 IP Address

Daylight saving time

Cancel

Save

Noted: Indoor Monitor can receive calls via SIP Server

The indoor monitor support received the call via the local network and the SIP server. The benefit of the SIP Server is that the door station and indoor monitor support public network calling, allowing communication between devices even when they are not within the same local area network (LAN). Devices can operate across different networks, providing greater deployment options.

- ◆ Step 7: Click Resident, then Add Resident to add a new resident.

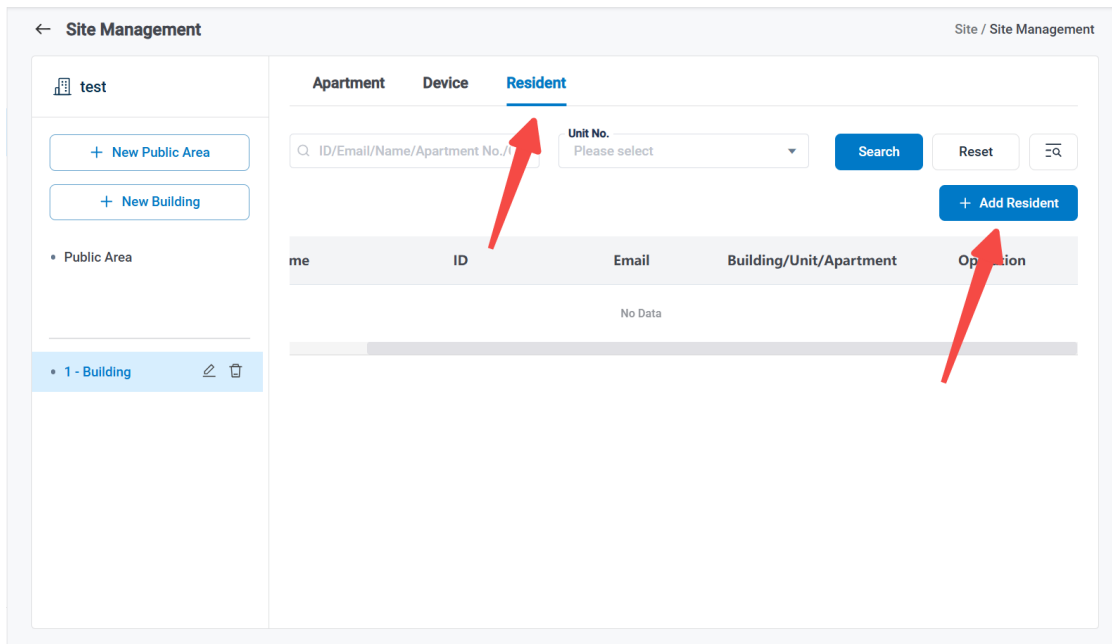

Noted: The cloud platform now supports using a single email account to join multiple households. The same account can act as the owner or a family member in up to 20 different households.

Additionally, a single email account can serve both as a household owner or member and as a community property manager at the same time.

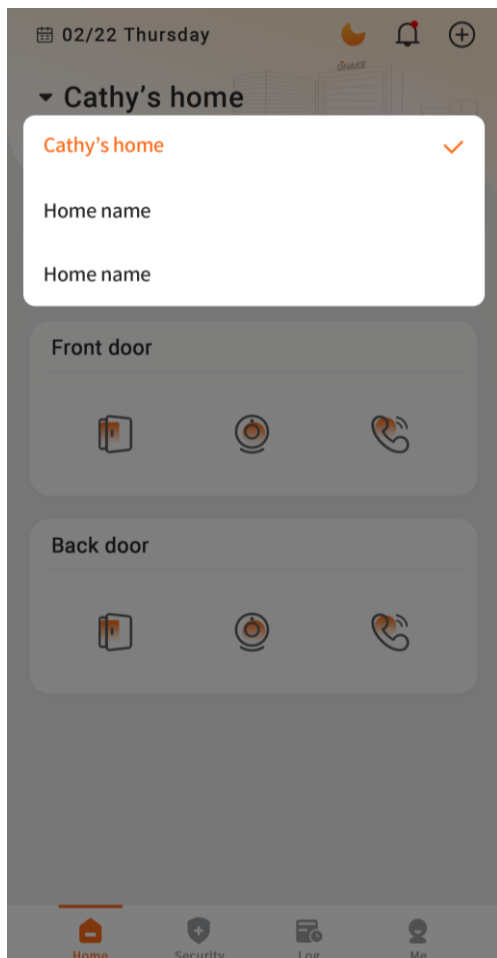

5.3.5 QR Code for Tenant Self-Registration

The system supports generating a unique QR code for each tenant. By simply scanning the QR code, tenants can independently complete the APP registration, bind their resident information, and associate with the devices—without requiring the property manager to manually enter email addresses or create accounts.

1. Here are the steps to generate a QR code for tenant self-registration

- ◆ Step 1: Go to the site and create a community. Fill in the necessary information, including name and country/region. And enable Register Account in the APP.

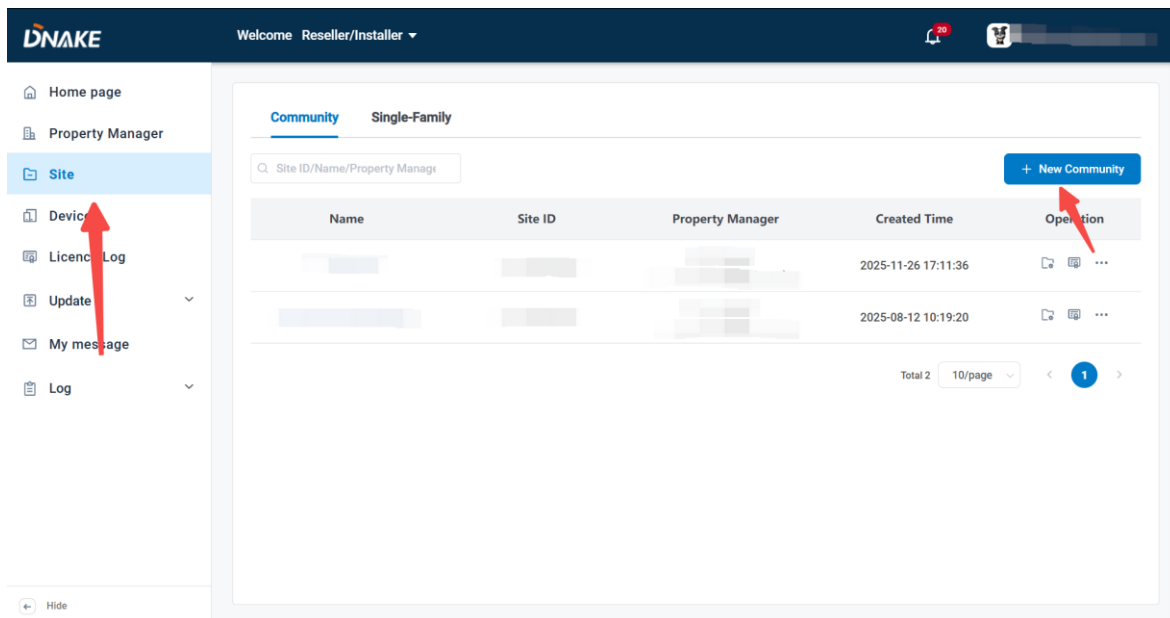

← Site / New Community

Community name * 0/30

Country/Region *
Please select ▼

Property Manager
Please select ▼

Email 0/60

Phone 0/15

Building structure
Building/Unit/Apartment ▼

Resident Permissions

Register Face ID in the APP Register Account in the APP



- ◆ Step 2: Go to the site created and create a new building.

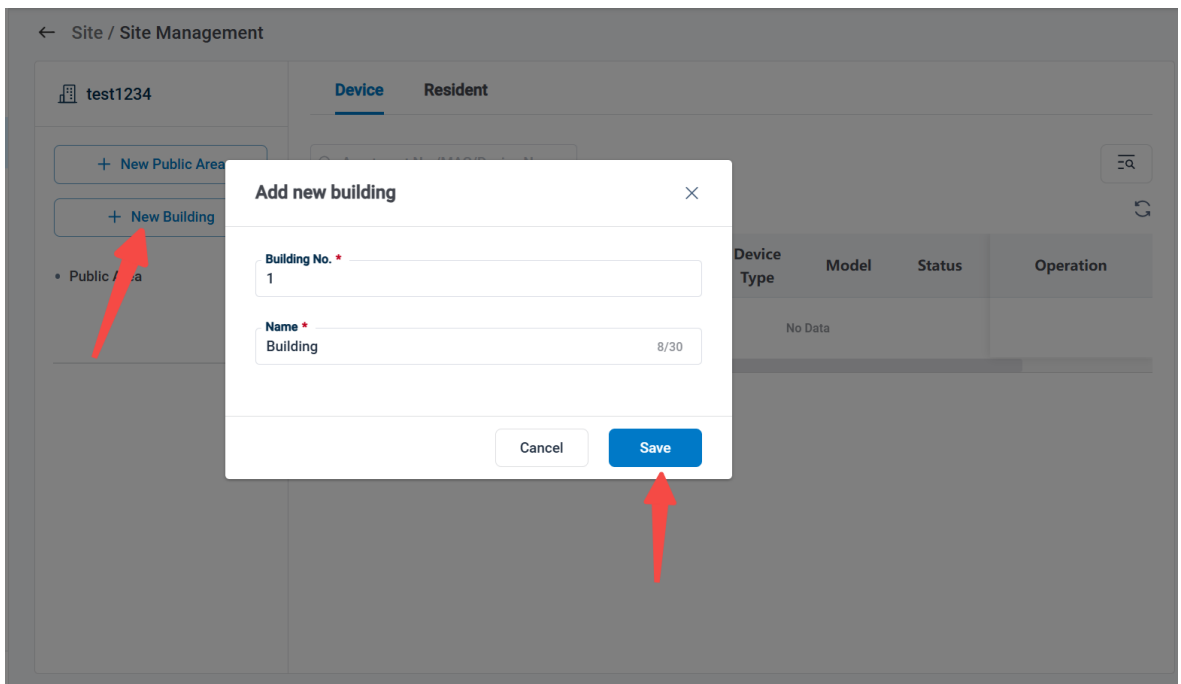

- ◆ Step 3: Select the building created and create a new apartment. And after selecting No Use or Without Indoor Monitor, the Generate Apartment QR Code will be shown. Enable it and set the scan times.

← Site / Site Management / New Apartment

Building No. *
1 - Building

Apartment No. *
Please fill in Apartment No.

License Selection *
Without Indoor Monitor

Generate Apartment QR Code

QR Code Expire Date
2025-12-03

Number of QR Code Scans
5

Add the resident (householder) to this apartment by the way ▾

Cancel Save

- ◆ Step 4: Click details of the dedicated apartment, and the QR code will be shown. It's allowed to download the QR code.

← Site / Site Management

Apartment Device Resident

+ New Public Area
+ New Building

• Parking Lot

• 1 - Building

Import Apartment Add Apartment

Building/Unit/Apartment	Call Type	Resident	Operation
1/1/3	App	0	Details
1/1/2	-	1	Details

Total 2 10/page 1

Apartment Details
×

Apartment Info

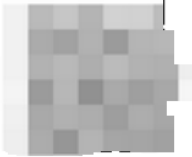
Building No.:	1 - Building
Unit No.:	1
Apartment No.:	2
Family Members:	1
Apartment QR Code:	<div style="text-align: center;">  <p>1-Building/1/2 Download</p> </div>
QR Code Expire Date:	2025-12-31
Remaining QR code scan times:	5

Other Info

License Selection:	Without Indoor Monitor
--------------------	------------------------

5.3.6 Landline

1. Here are the steps to enable the landline feature

- ◆ Step 1: Make sure the device added can support the landline feature.
- ◆ Step 2: Navigate to Site, click Community, select the desired community, then choose the corresponding building to check the apartments.

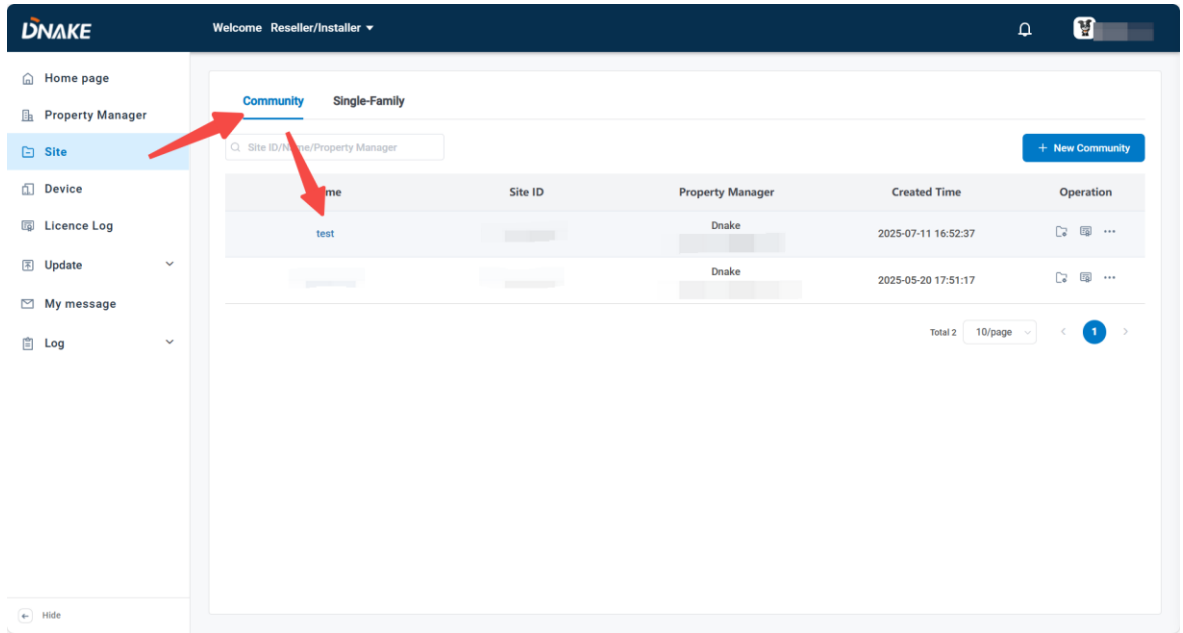

- ◆ Step 3: Click Edit to open the settings for the apartment you want to configure the landline for

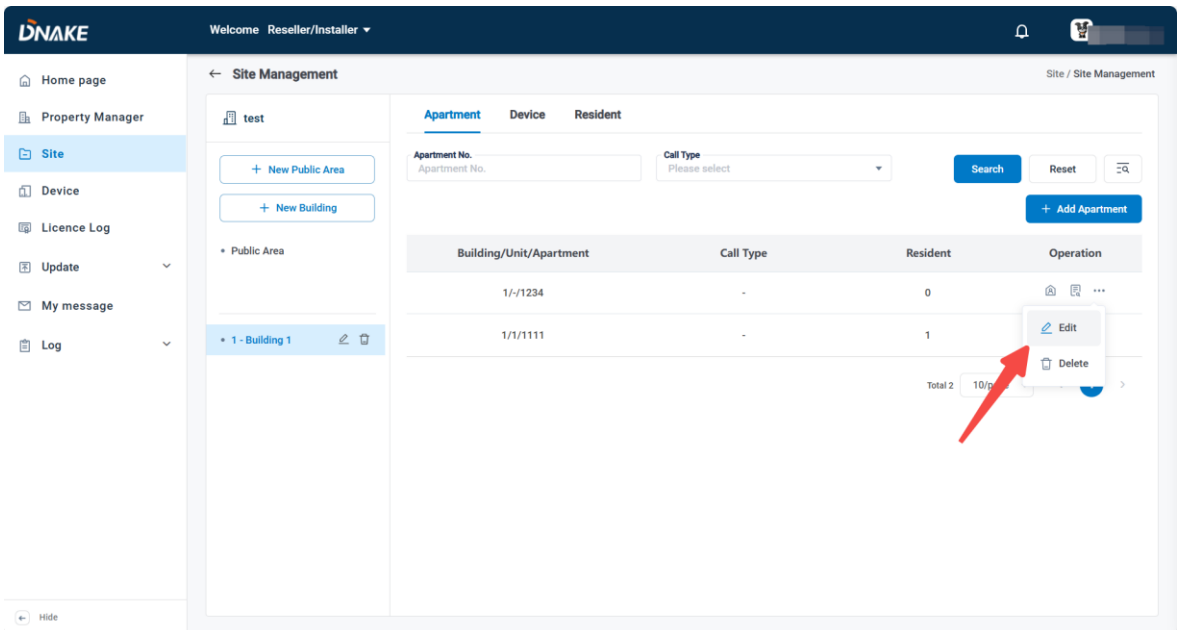

- ◆ Step 4: Enable Value-added Services, then select the call type and fill in the phone number you want to use

Value-added Services

Expire Date
2026-08-21 [🔗](#)

Call Type
Landline

App

Landline

Call the App first, then transfer to landline

+54 0/15

2nd Landline

+54 0/15

3rd Landline

+54 0/15

Cancel OK

5.3.7 Add a Single-Family

1. Here are the steps to create a single-family

- ◆ Step 1: Click Single-Family, then New Single-Family to add a new single-family.

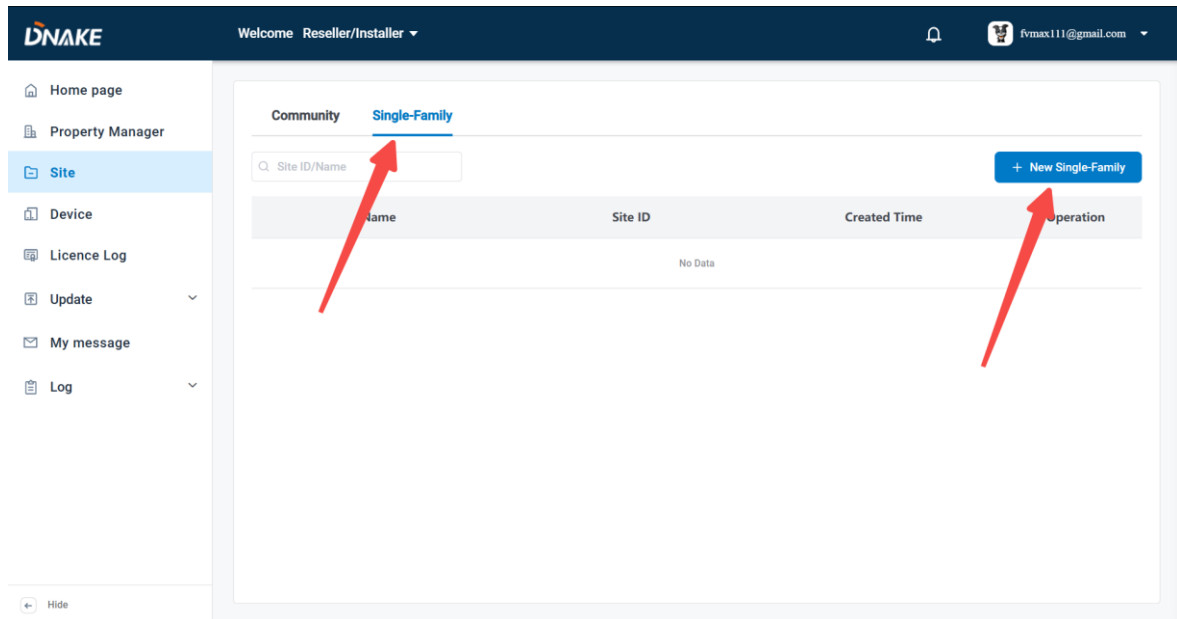

- ◆ Step 2: Click Single-Family, then New Single-Family to add a new single-family. Name, country/region, and license selection are necessary. You can select to add a device to this site on the same page.

← **New Single-Family**

Name * 0/30

Country/Region *

Language *

License Selection * ?

[Add the device to this site by the way](#) ▼

- ◆ Step 3: Click Device, then Add Device to add a new device to this site.

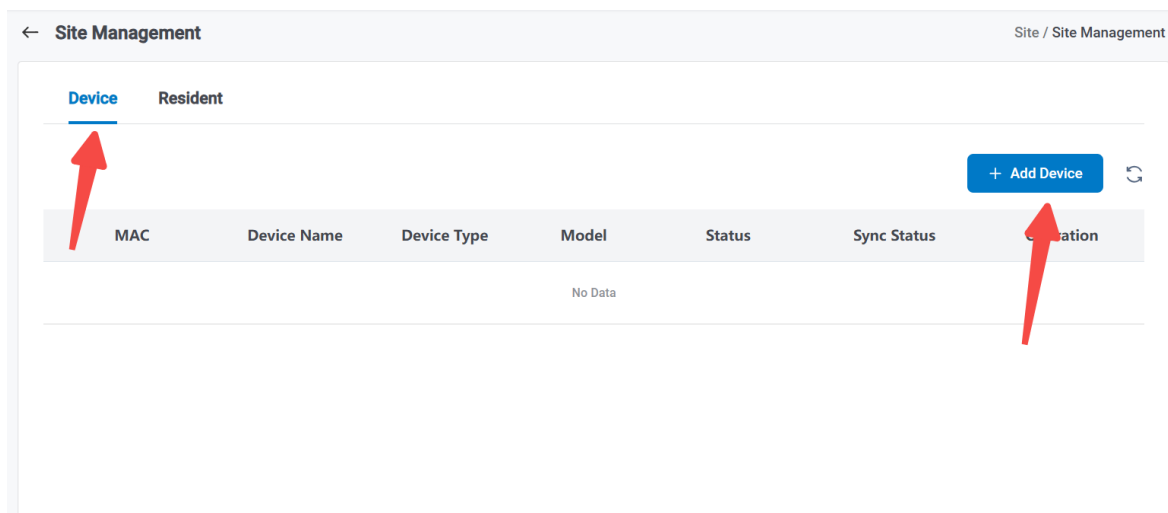

- ◆ Step 4: Click Resident, then Add Resident to add a new resident.

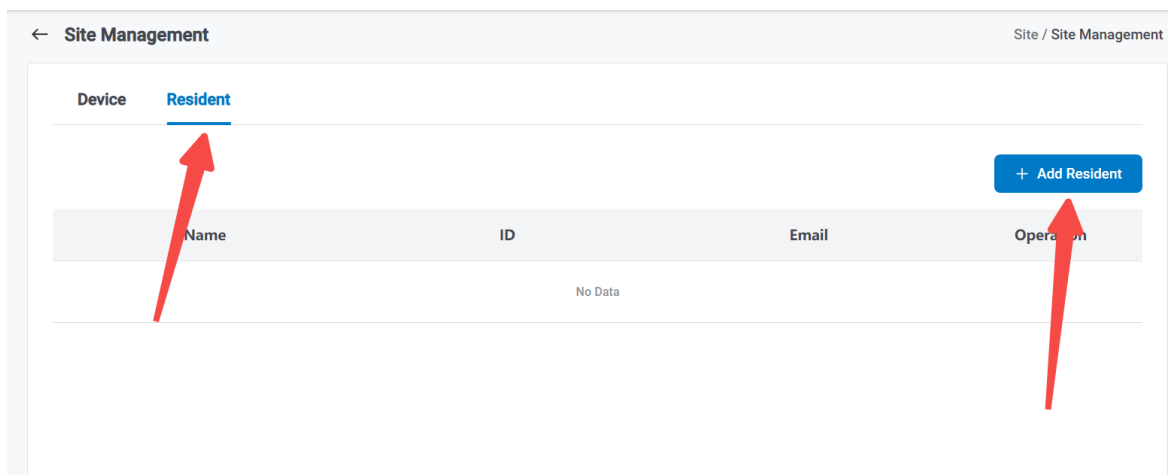

←
New Resident

Name *

0/30

APP Function

ⓘ

Email *

0/60

Phone

(Albania) +355

▼

Please fill in Phone

0/16

Language *

English

▼

(Email send to users will be in language users choose)

Cancel

Save

5.3.8 Report Device Anomalies

1. It is used to send a report to the administrator's email when an abnormality occurs on the device.

DNAKE

Welcome Reseller/Installer ▾

Note ×

- Home page
- Property Manager
- Site
- Device
- Licence Log
- Update
- My message
- Log

←
New Community

Access Control Permission

Config Private Devices on the Platform ⓘ

Remote Management

ⓘ

Daylight saving time

ⓘ

Sync Resident to phonebook by default

ⓘ

Report Device Anomalies

ⓘ

Thresholds for ON/OFF Line Anomaly *

ⓘ

Report to 1st Email *

0/40

Report to 2nd Email

0/40

Report to 3rd Email

0/40

Remarks

0/200

Cancel

Save

Description

It is used to configure whether to send a report to the administrator when an abnormality occurs on the device.

Configuration

-Valid values : Enable/Disable

-Default value : Disable

5.4 Device

5.4.1 Add Device

5.4.1.1 Add in Batch

1. Here are the steps to add devices in batch

Step 1: Go to the Device column and click Import Device Bottom.

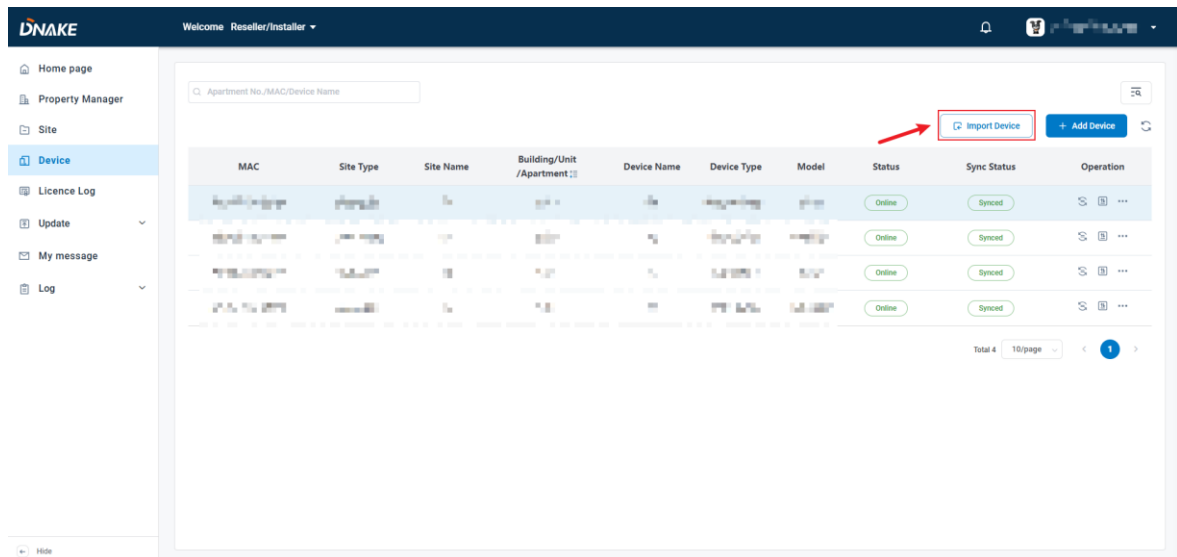

Step 2: After clicking Import Device, you can click Note to view the Template Fields, click Template to fill in the devices' information, and click Import to upload the completed template.

Import Device ×

Note :

Template :

Import :

Noted: Indoor Monitor can receive calls via SIP Server

The indoor monitor support received the call via the local network and SIP server. The benefit of the SIP Server is that the door station and indoor monitor support public network calling, allowing communication between devices even when they are not within the same local area network (LAN). Devices can operate across different networks, providing greater deployment options.

5.4.1.2 Add One by One

- ◆ Step 1: Step 1: Go to the Device column and click Add Device to add a device.

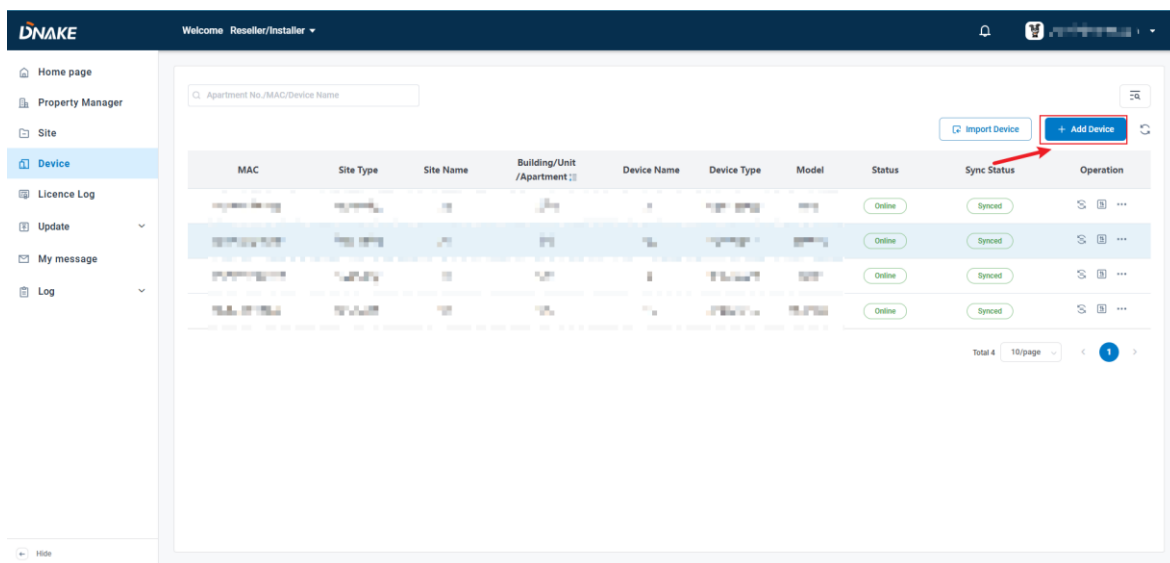

- ◆ Step 2: Select the site and fill in the device’s information. Device Type, MAC address, device number, and device name should be filled in or chosen according to your device and needs. All of the other settings will be synced to your device.

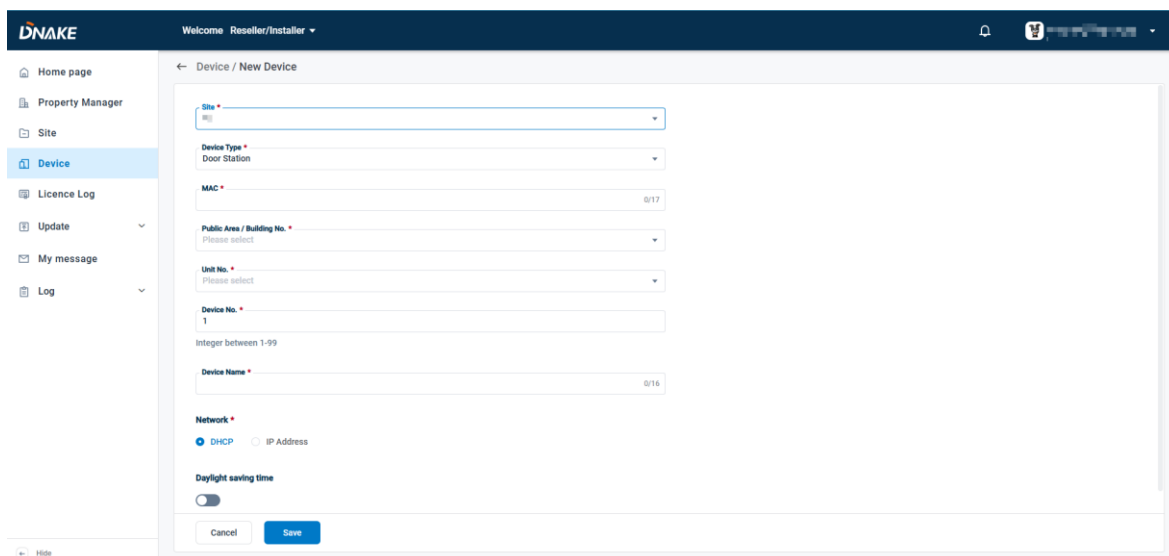

Noted: When adding devices to **Community**, the **Applying Area** option allows you to specify whether the device is **Private** or **Public**.

- **Private:** The device cannot be added to the **Access Rule** by the

property manager. It will not appear in the device list under **Access Rule**.

- **Public:** Vice versa.

5.4.1.3 Automatic Device Deployment to the Cloud Platform

- ◆ Step 1: Create a project on the cloud platform. For detailed instructions, refer to section 5.3.1.
- ◆ Step 2: Enter the Site ID in the designated field and enable "Automatic Deployment" by toggling the switch. Then, fill in the Building No, Unit No, and Room No fields accordingly.

5.4.2 Replace Device

It's only supported to replace a device with the same model.

1. Here are the steps to replace a device

- ◆ Step 1: Go to the Device column and click Replace Device to replace this device.

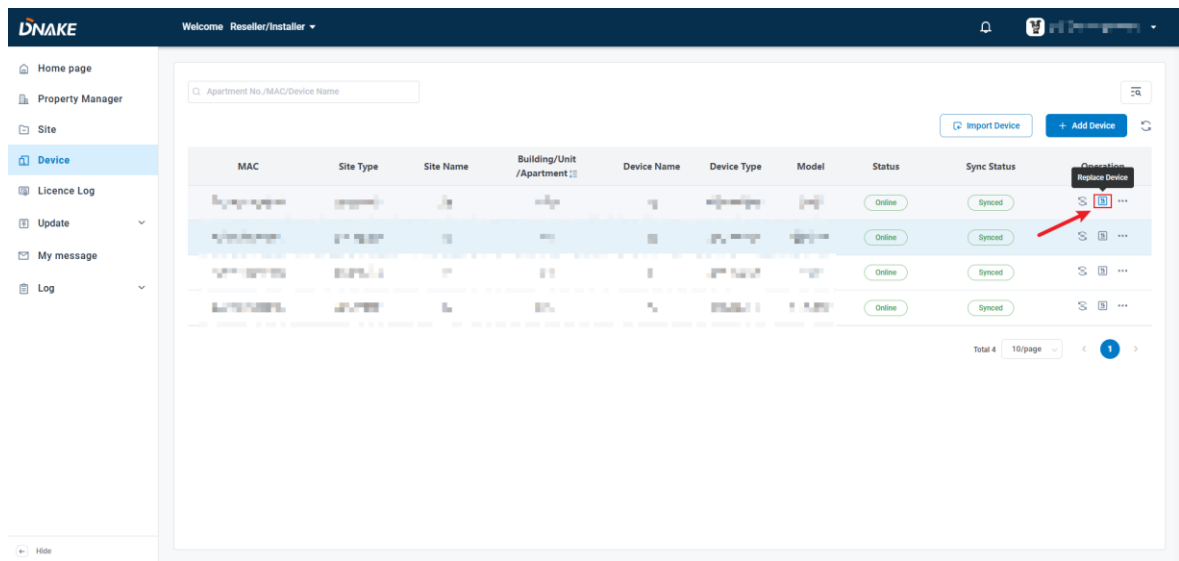

- ◆ Step 2: Fill in the MAC address of the new same-model device. You can also change its network.

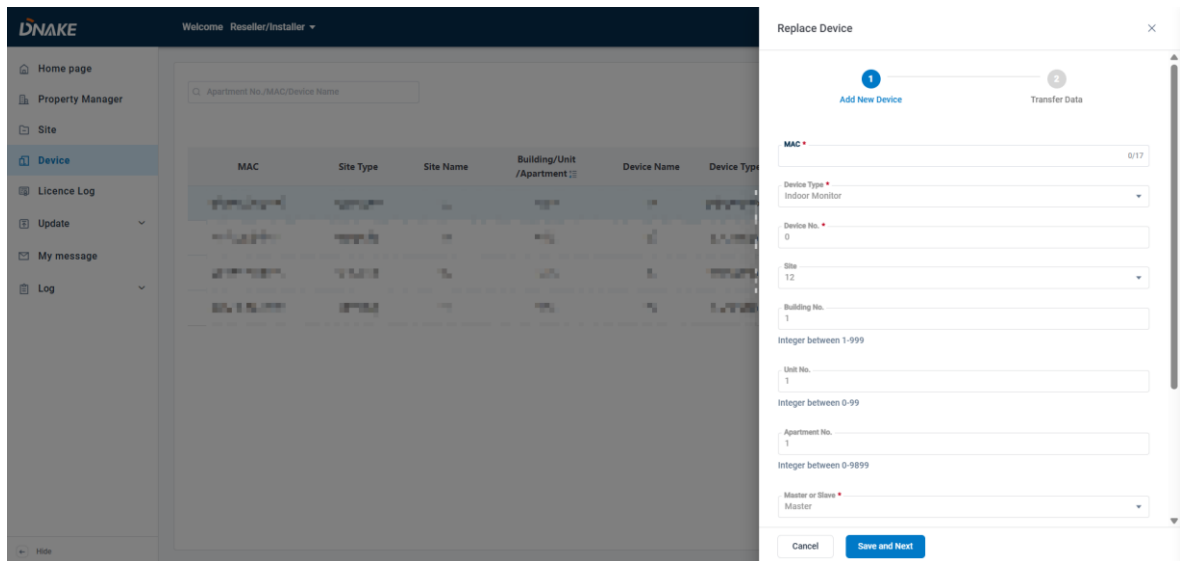

- ◆ Step 3: The platform will check the status of the device.

Device Status

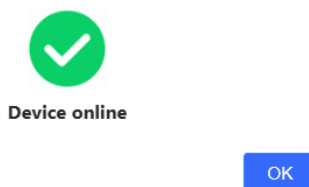

- ◆ Step 4: After that, the data will be transferred to the new one.

Replace Device

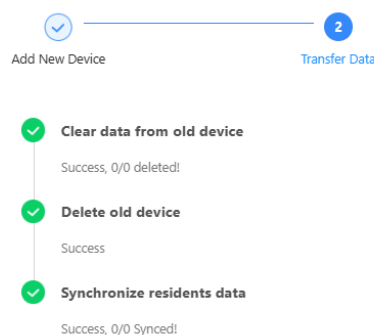

Finish

5.4.3 Access Device Webserver

1. Here are the steps to access the device web server

- ◆ Step 1: Make sure the device firmware is the latest with FRP service.
- ◆ Step 2: Visit the device’s config page with its IP address locally. The default account is admin, and the password is 123456.
- ◆ Step 3: Go to System > Remote Access to allow this feature.

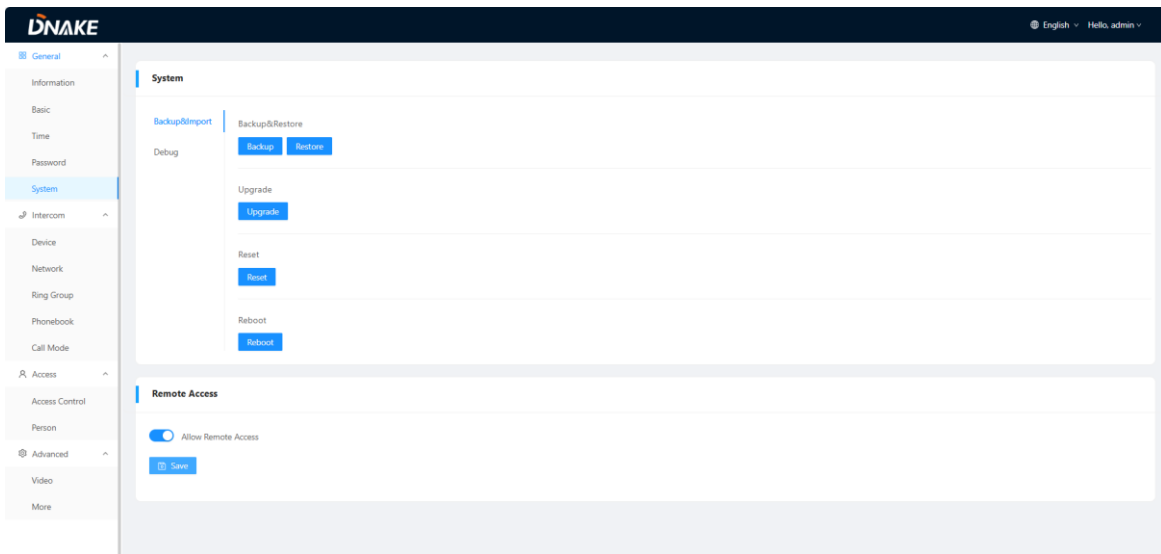

- ◆ Step 4: Go back to the cloud platform's Device > More > Access Device Webservice

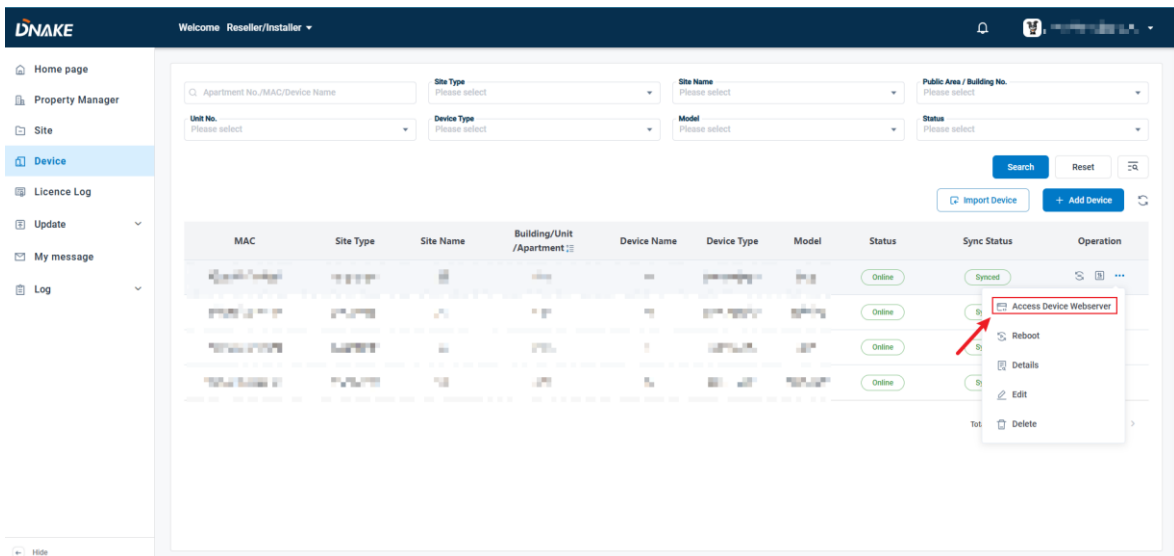

- ◆ Step 5: Click Open to browse. The device web server will open in a new window. Access will remain valid for 30 minutes.

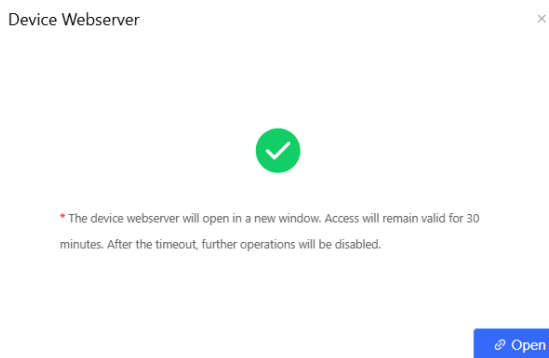

5.4.4 Device Relay Setting

- ◆ Step 1: Go to the Device column and click More > Relay Setting behind the device to configure the relay.

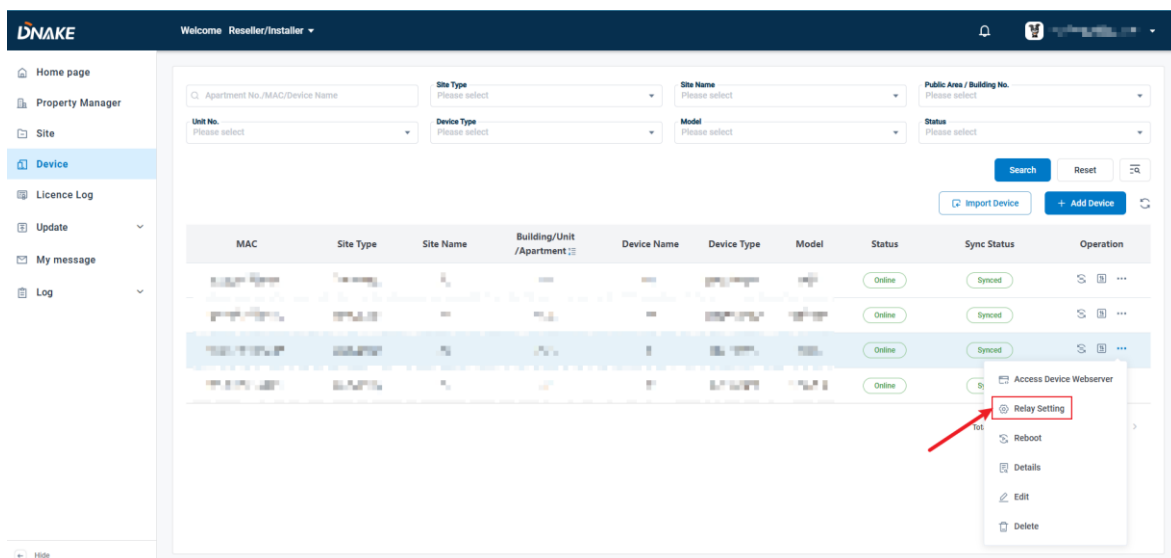

- ◆ Step 2: Select the relays you need and configure the relay and dry contact by yourself. When residents log in to Smart Pro and click the unlocking button of the entrance device, relays with inactive status in the relay list will be hidden. When there is only one relay in an "active" state on the entrance device, clicking the unlocking button will skip the relay list

selection and directly unlock the door.

Relay Setting
✕

| **Relay Configure** 🔗

Status	Relay No.	Name	DTMF	Unlock Delay	Unlock Time
<input checked="" type="checkbox"/>	Relay1	<input type="text" value="Relay1"/> 6/20	#	0S	3S
<input checked="" type="checkbox"/>	Relay2	<input type="text" value="Relay2"/> 6/20	0	0S	3S
<input checked="" type="checkbox"/>	Relay3	<input type="text" value="Relay3"/> 6/20	*	0S	3S

| **Dry Contact Input Configure** 🔗

Dry Contact Input	Type	Action
Dry Contact Input1	Exit Button	Relay1
Dry Contact Input2	Exit Button	Relay2
Dry Contact Input3	Exit Button	Relay3

Cancel
OK

5.4.5 Reboot the Device.

- ◆ Step 1: Go to the Device column and click More > Reboot behind the device to configure the relay.

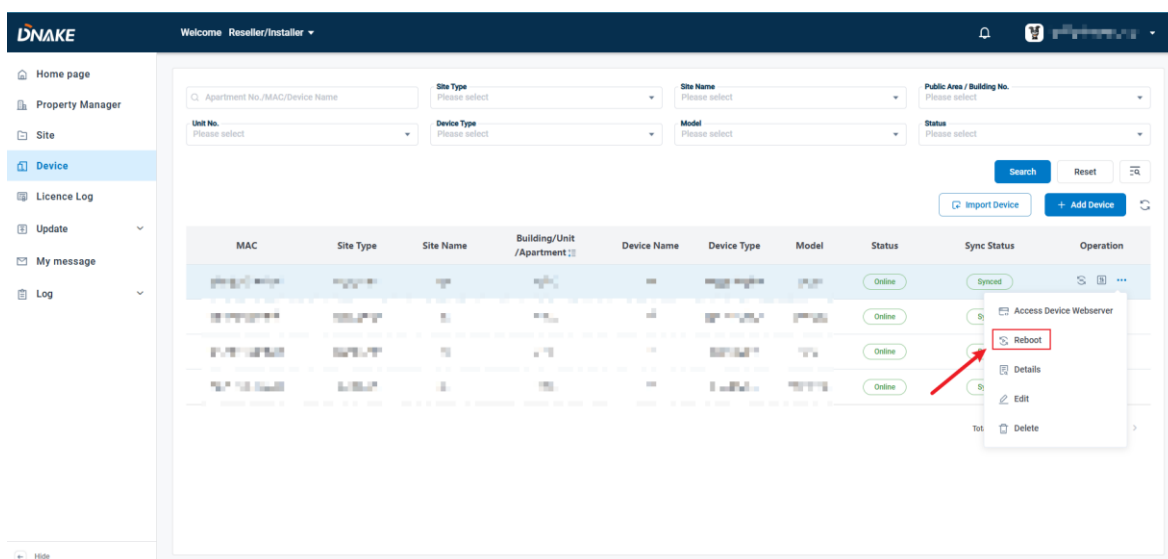

5.4.6 Enable Daylight Saving Time

- ◆ Step 1: Click More, then Edit.

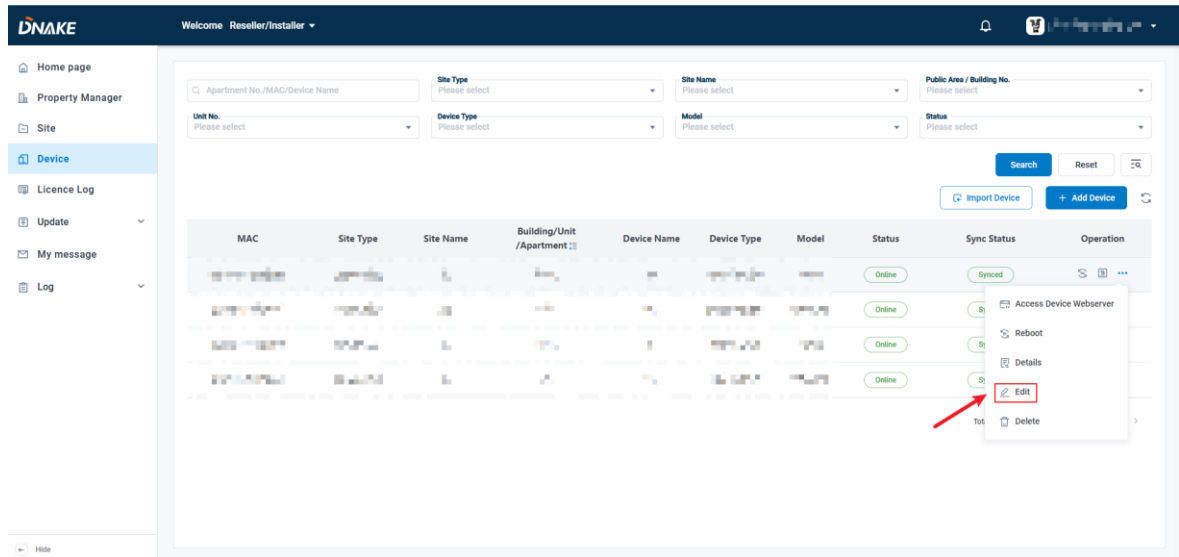

- ◆ Step 2: Enable daylight saving time.

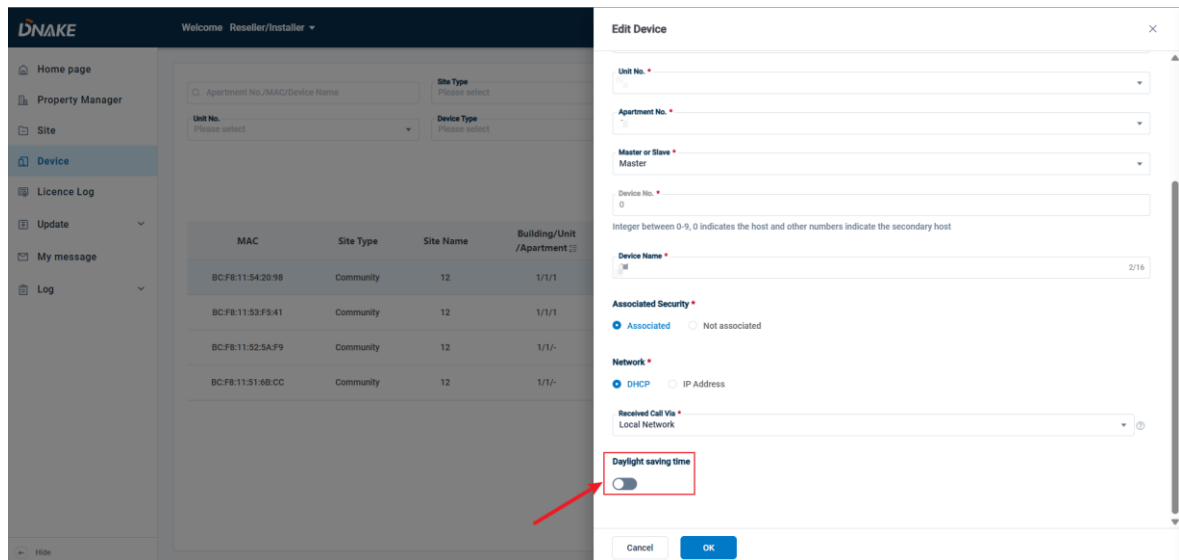

5.5 License Log

1. You can check the number of licenses you have and the license log.

Summary Cards:

- 15 With Indoor Monitor
- 13 Without Indoor Monitor
- 16 Value-added Services
- 5 Remote Management

Search and Filter Options:

- Source/Destination: [Input]
- Time: Start Time [Input] - End Time [Input]
- Type: Please select [Dropdown]
- Operation: Please select [Dropdown]
- Buttons: Search, Reset, Export

Item	Time	Type	Operation	Amount	Source/Destination	Holdings	Remarks
1	2025-08-18 08:14:45	With Indoor Mon...	Issued To Subor...	-1	[Redacted]	15	-
2	2025-08-18 08:14:45	Without Indoor ...	Recovered By Su...	+1	[Redacted]	13	-
3	2025-08-14 21:22:54	Without Indoor ...	Issued To Subor...	-1	[Redacted]	12	-
4	2025-08-13 11:27:06	With Indoor Mon...	Recovered By Su...	+1	1	16	-
5	2025-08-13 11:27:06	Without Indoor ...	Recovered By Su...	+1	1	13	-

5.6 Update-Firmware List (OTA)

1. Choose the corresponding Device Type, Model, and Firmware Version according to the device. After choosing, the devices can be selected to upgrade, and Upgrade Time can also be set.

Form Fields:

- Device Type: Door Station [Dropdown]
- Model: Please select [Dropdown]
- Firmware Version: Please select [Dropdown]
- Upgrade Time:
 - Upgrade Now
 - Schedule Upgrade

Site	Device Name	MAC	Firmware Version	Status
No Data				

Buttons: Cancel, Save

5.7 Update-Upgrade Log (OTA)

1. The log of the upgrade.

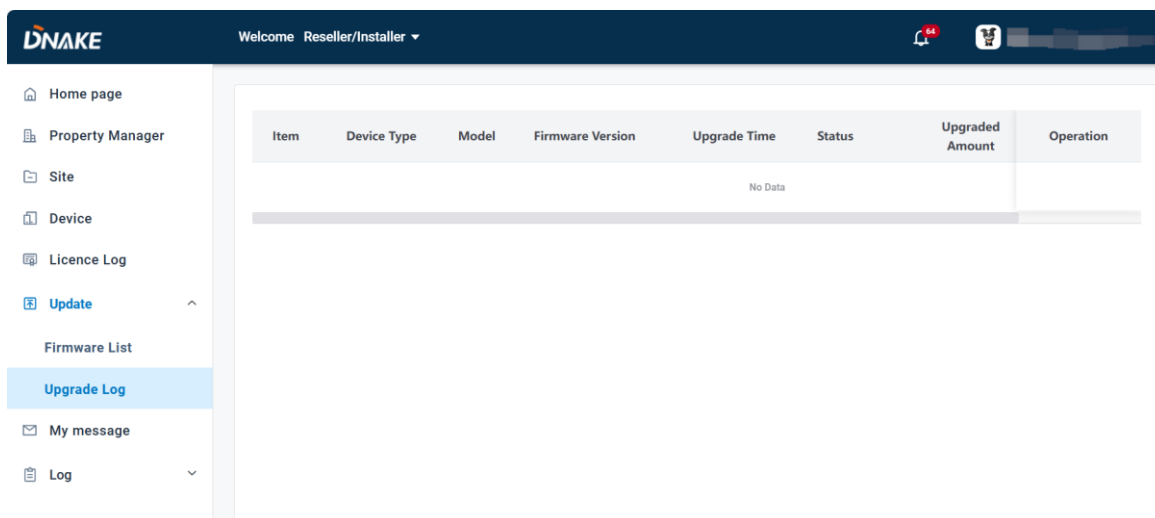

5.8 My Message

5.8.1 Send Messages to Property Manager

1. Here are the steps to send messages to the property manager

- ◆ Step 1: Go to the My message column and click Add to edit a message.

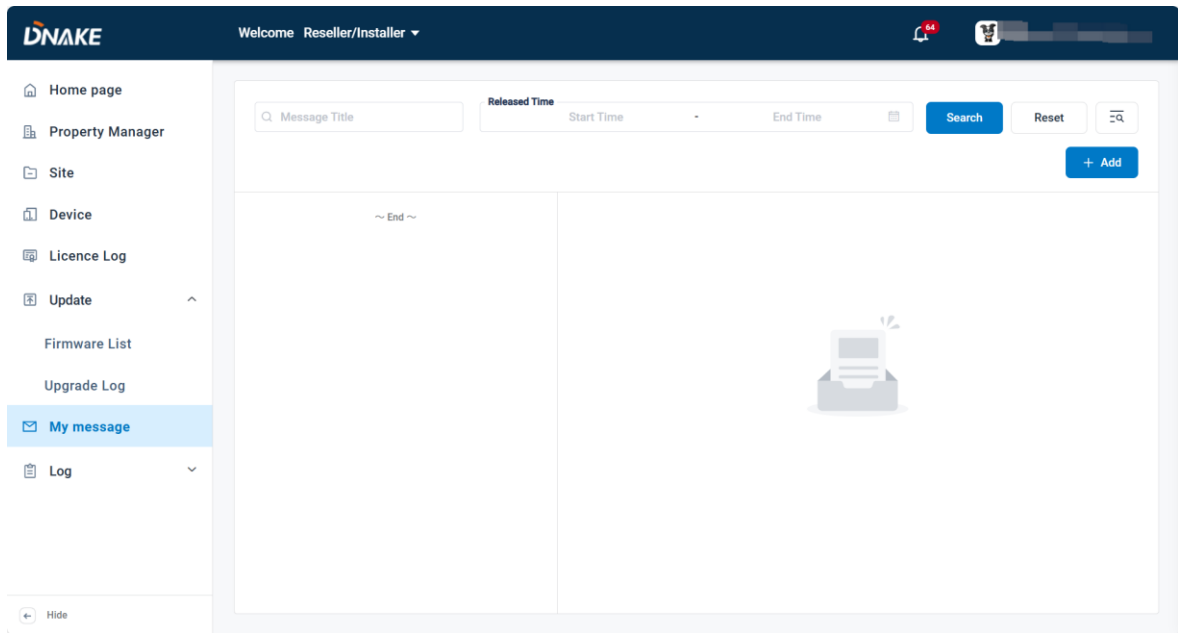

- ◆ Step 2: Fill in the message title and message content. Choose the recipient and the delivery time.

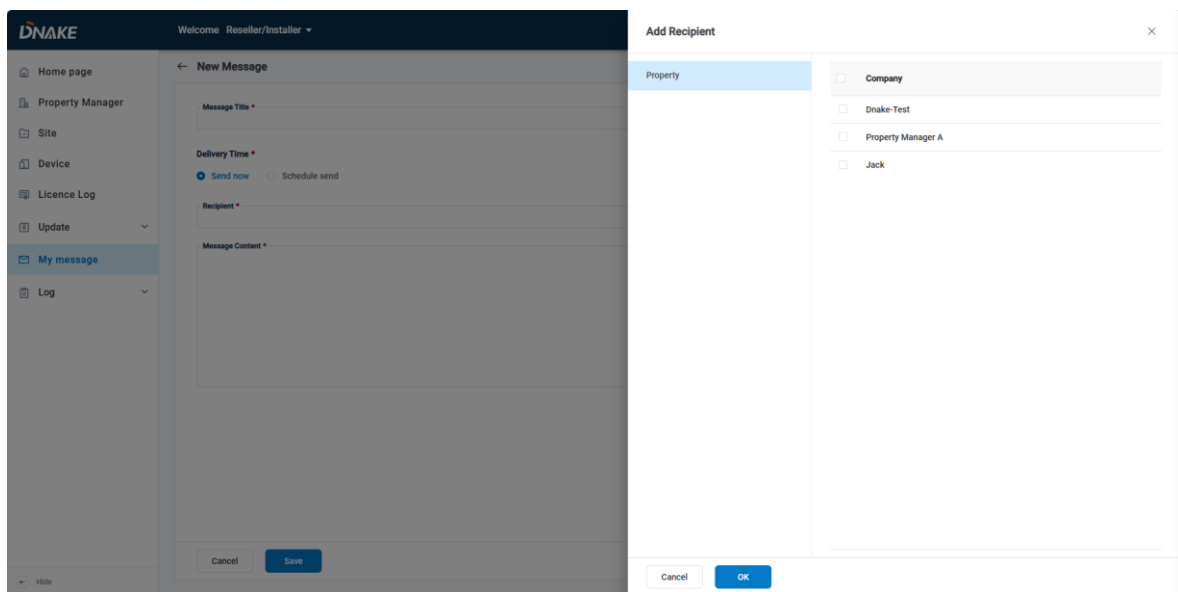

- ◆ Step 3: Click the message. You can check the message details.

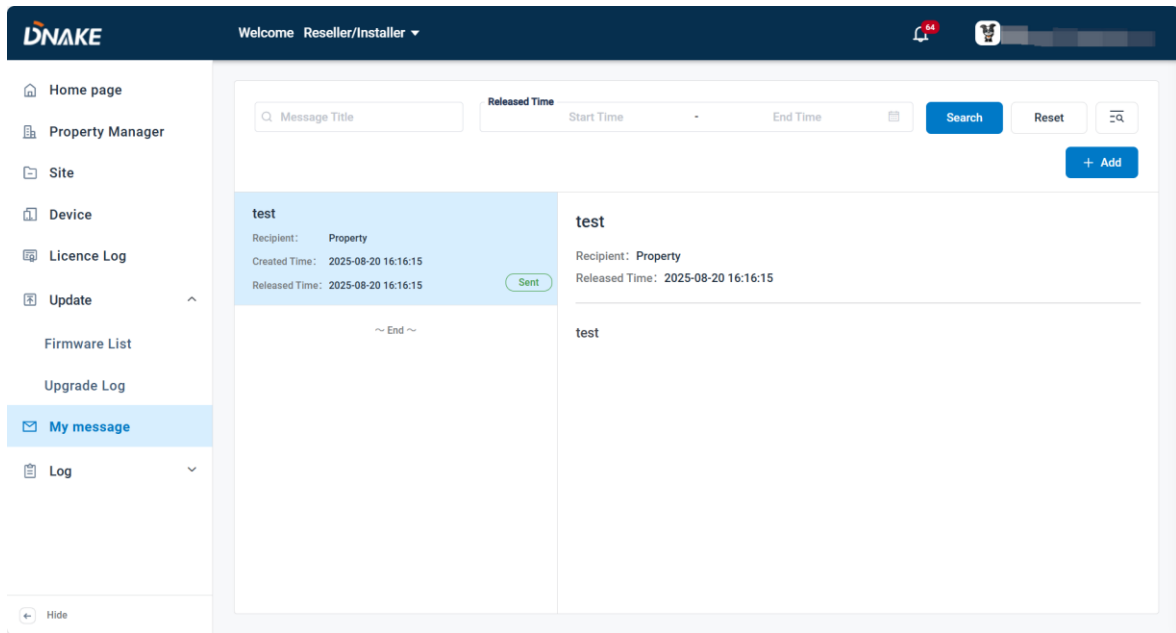

5.9 Log

5.9.1 Configuration Log

1. You can check the configuration logs of this community's devices. You can view the records for recent one month.

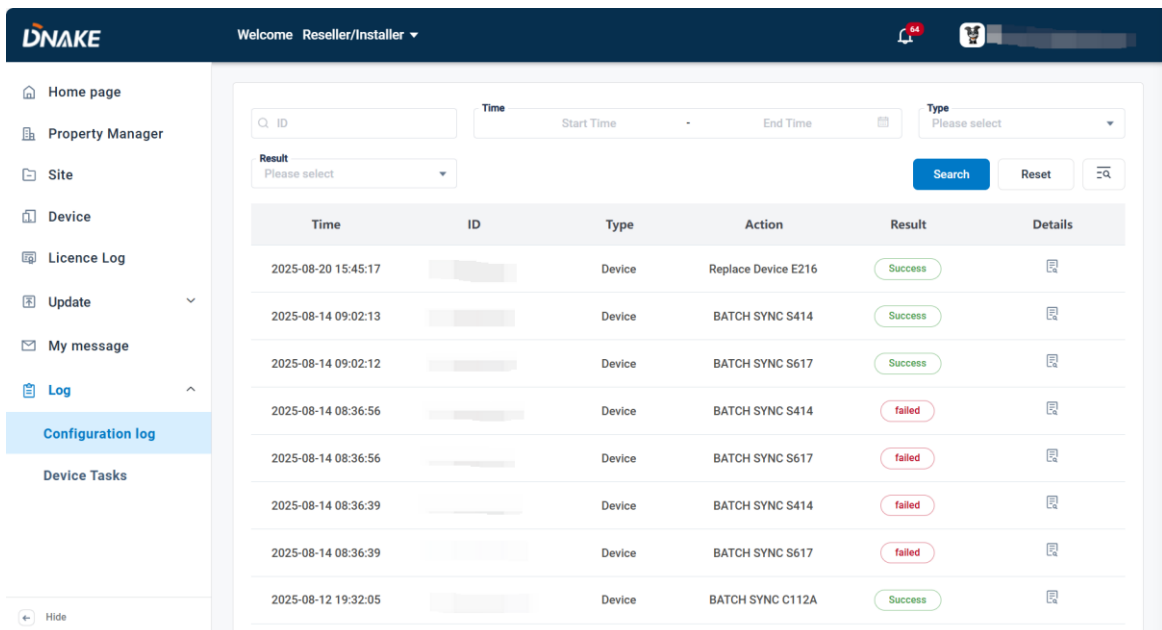

5.9.2 Device Tasks

1. Here, records operation logs related to device management, including deletion and replacement activities, ensuring traceability and accountability.

Item	Task Type	Site	Device Name	Device Type	Residential Information	MAC	Submit Time	Status
1	Delete Device	test	C112A	Villa Station	1/1/1111		2025-08-12 19:17:13	Success
2	Delete Device	demo case	S617 SIP	Door Station	1/1/-		2025-07-25 16:15:19	Success
3	Delete Device	demo case	E217W	Indoor Monitor	1/1/1111		2025-07-25 16:15:15	Success
4	Delete Device	demo case	S213K	Villa Station	1/1/1111		2025-07-25 16:15:06	Success
5	Delete Device	demo case	C112	Villa Station	1/1/1111		2025-07-25 16:15:01	Success
6	Delete Device	demo case	S414	Door Station	1/1/-		2025-07-11 16:54:04	Success
7	Delete Device	test	S617	Door Station	1/1/-		2025-07-09 11:23:19	Success
8	Delete Device	test	E216D	Indoor Monitor	1/1/1111		2025-06-26 15:13:59	Success
9	Delete Device	test	E214E	Indoor Monitor	1/1/1111		2025-06-24 09:19:11	Success
10	Delete Device	test	E217W	Indoor Monitor	1/1/1111	A	2025-06-24 09:17:41	Success

5.10 Switch to Property Manager

1. Please make sure you linked the project to this Reseller/Installer account when creating it. After doing so, you may find you can switch to manage the project in the upper right corner. You can also switch back to Reseller/Installer.

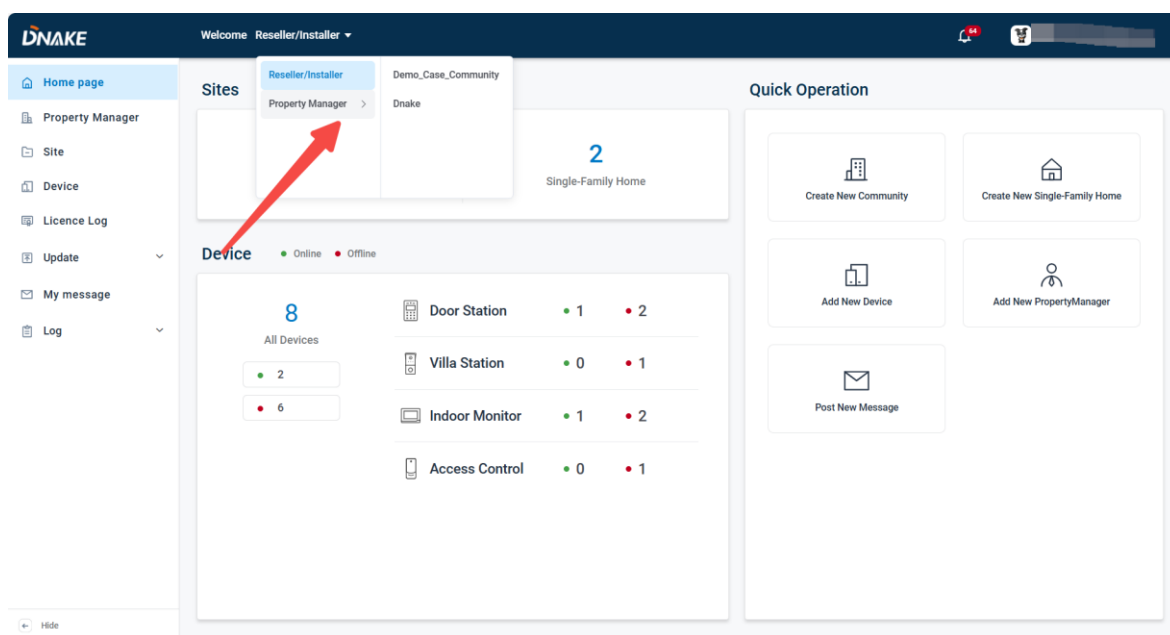

Noted: In our system, a **site** can be defined as a **single-family house** or a **community**. A single-family house normally does not have property management, which means it cannot be managed under a property management account. By contrast, a community site is managed by a property manager, so when we switch to the property management account, only **community** sites can be managed.

5.11 Technical Supporter

1. Here are the steps to create the contact for the Property Manager to seek technical support.

- ◆ Step 1: Go to Account > Technical Supporter.

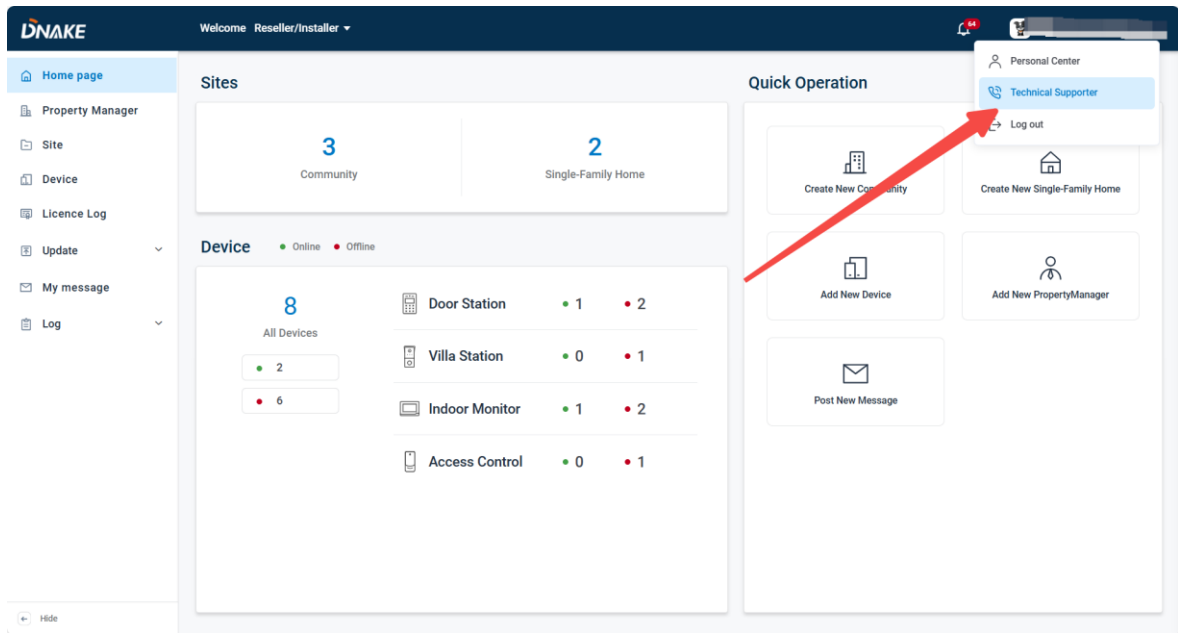

◆ Step 1: Fill in the information about the technical support.

Technical Supporter
×

⚠ Leave contact information to property managers for technical support

Name

Phone Number

Email

Cancel
OK

6. Property Manager

6.1 Home Page

The dashboard provides an overview of the system's main functions.

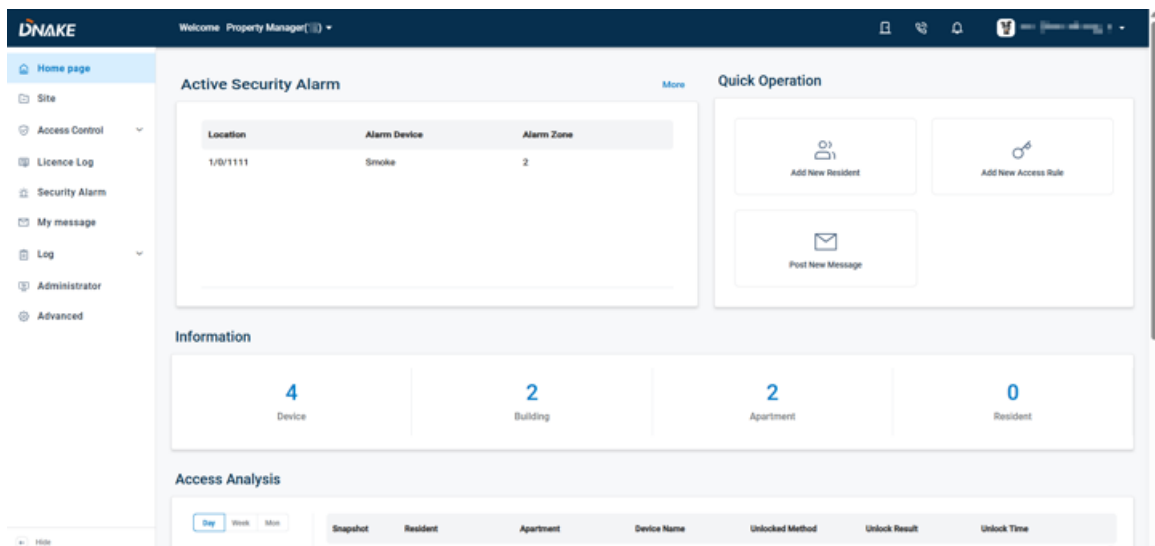

6.1.1 Security Alarm

1. The Active Security Alarm section displays real-time alarm information, including the location, the device that triggered the alarm, and the corresponding alarm zone. You can click more to check more alarms.

Active Security Alarm More

Location	Alarm Device	Alarm Zone
1/0/1111	Smoke	2

6.1.2 Quick Operation

1. Quick Access panel allows administrators to quickly add new residents, create new access rules, or post announcements and notifications to residents.

Quick Operation



Add New Resident



Add New Access Rule



Post New Message

6.1.3 Information

This area gives a summary of system resources, showing the number of connected devices, configured buildings, registered apartments, and residents.

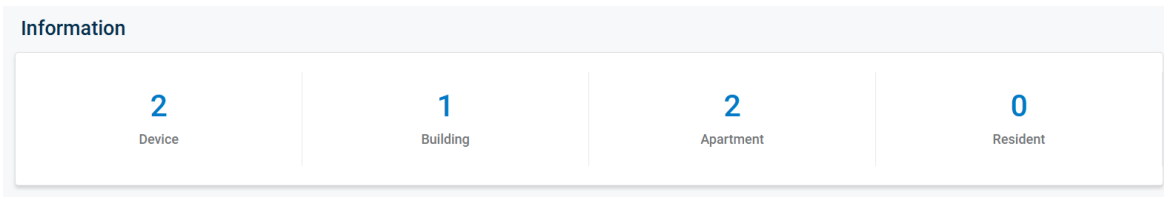

6.1.3 Access Analysis

Here, administrators can view whether an entry attempt was successful or failed, check snapshots taken during the attempt, identify the resident and their apartment, and see details such as the device used, the unlocking method, the result, and the exact time of the event. The system displays up to the latest ten records for review, and it also provides daily, weekly, and monthly reports for statistical analysis.

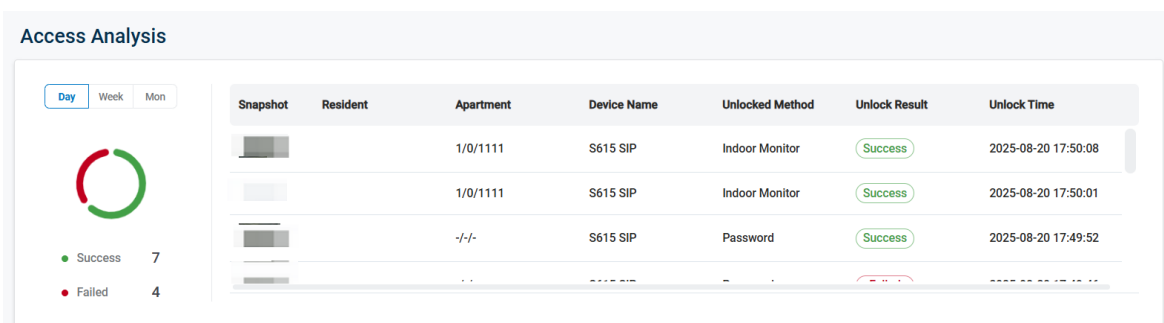

6.1.4 Call Analysis

Here are statistics on communication activities. It records the total call duration and allows the data to be viewed by day, week, or month, giving administrators insight into system usage.

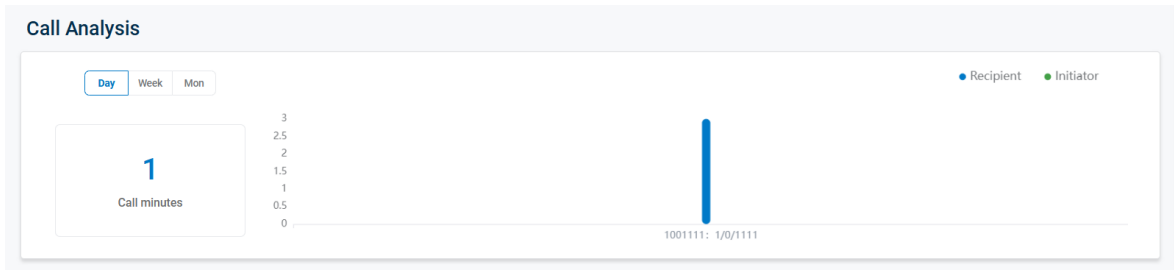

6.2 Site

6.2.1 Device Management

6.2.1.1 Synchronize All Residents' Data

1. If it failed to sync, you can click it to sync manually.

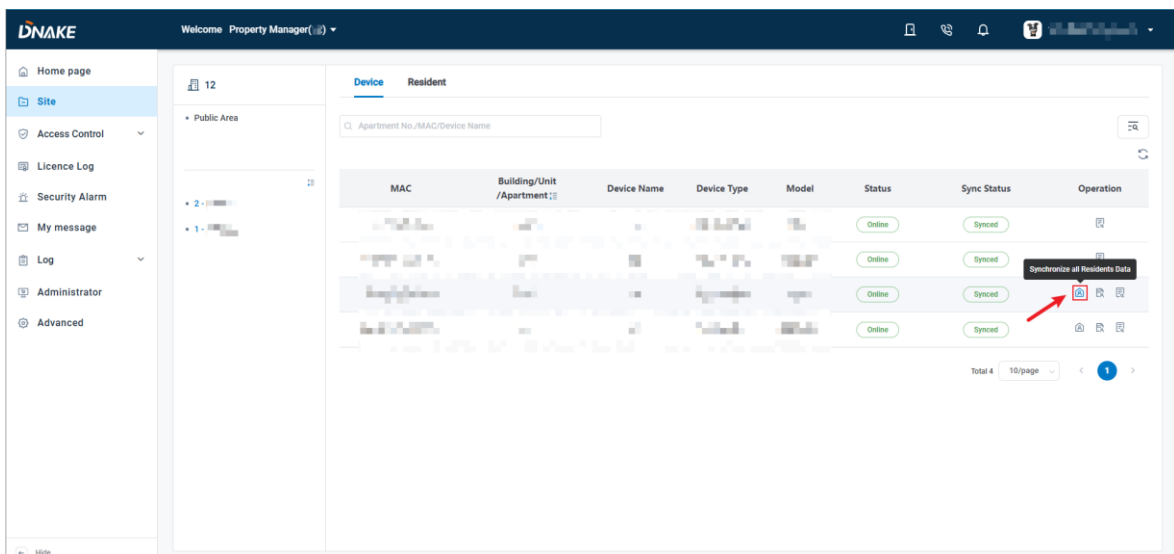

6.2.1.2 Resident Details

1. The configuration items related to video service and re-synchronize failed apartments have been centralized and integrated into the editing page of the

resident details.

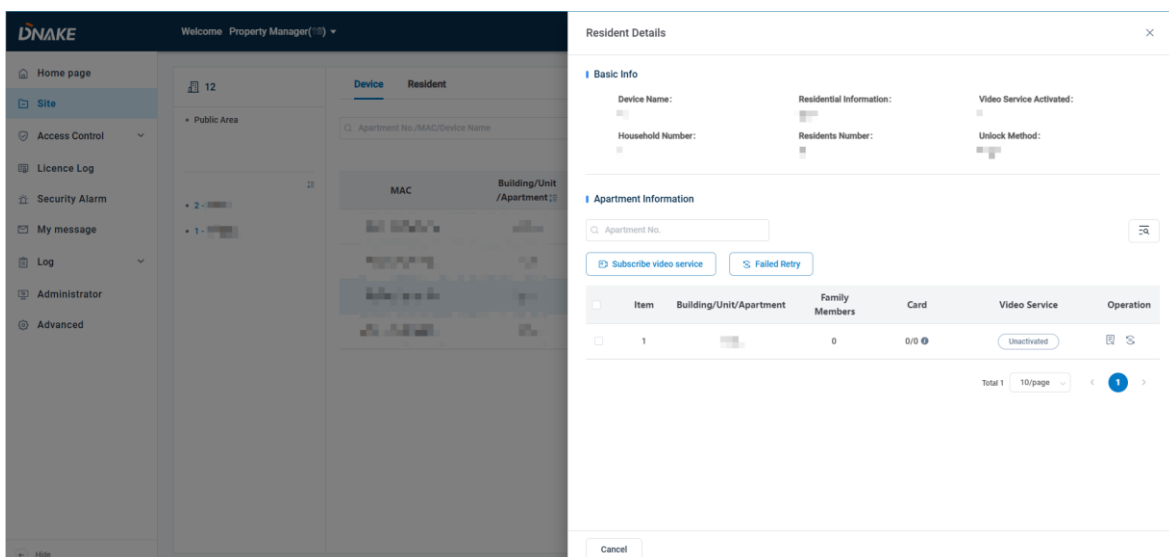
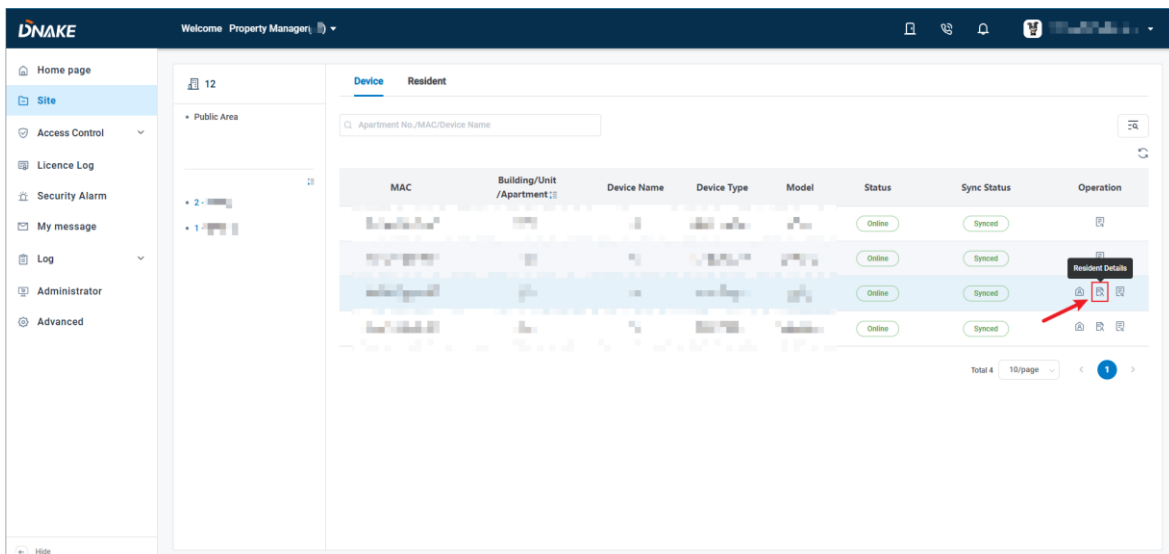

6.2.2 Apartment Management

6.2.2.1 Resident

Click the Resident icon to access the Resident module, where you can view and manage all users within the same Building, Unit, or Apartment.

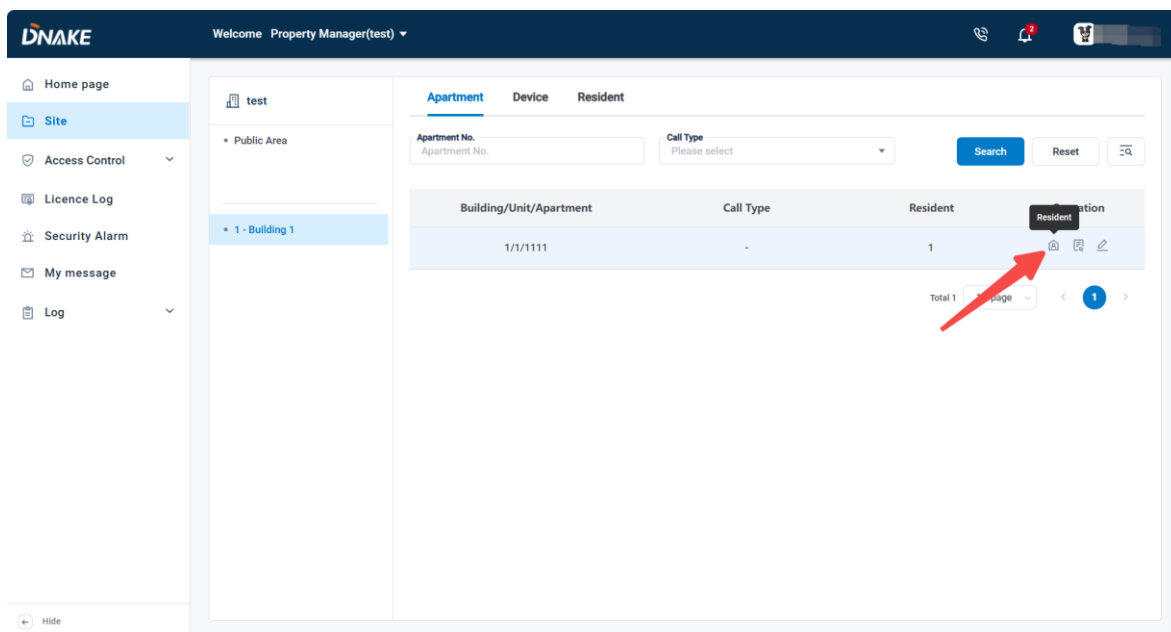

6.2.2.2 Details

The Apartment Details section provides an overview of the selected apartment, showing its Building, Unit, and Apartment numbers, the number of family members, and service-related settings such as video permission, value-added services, call options, and video service status.

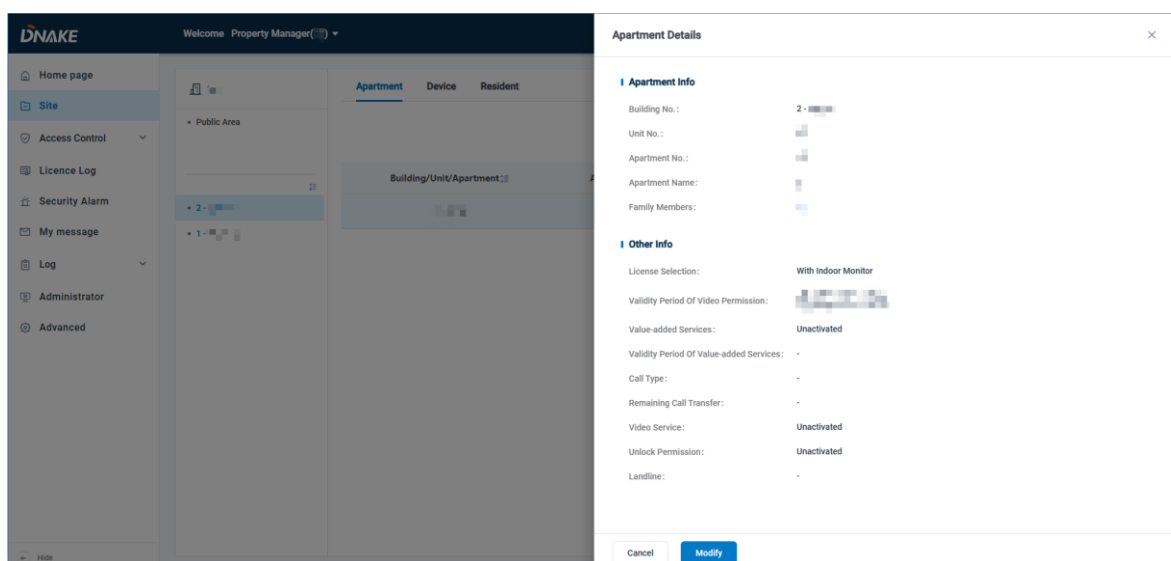

6.2.2.3 Edit

Here you can modify the apartment's video service settings for the residents' app account. Unlock permission for each device can also be granted or cancelled for every app account under this apartment.

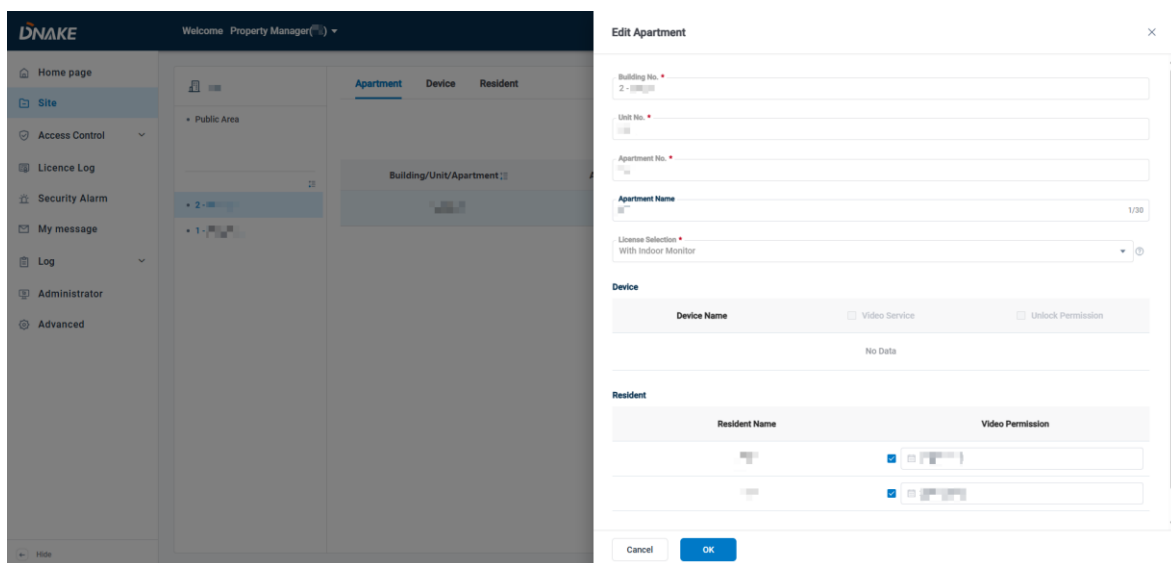

6.2.3 Resident Management

6.2.3.1 Add a New Resident

1. Here are the steps to create a new resident

- ◆ Step 1: Go to the Site column and select the desired building, then click Resident and choose Add Resident to add a new resident.

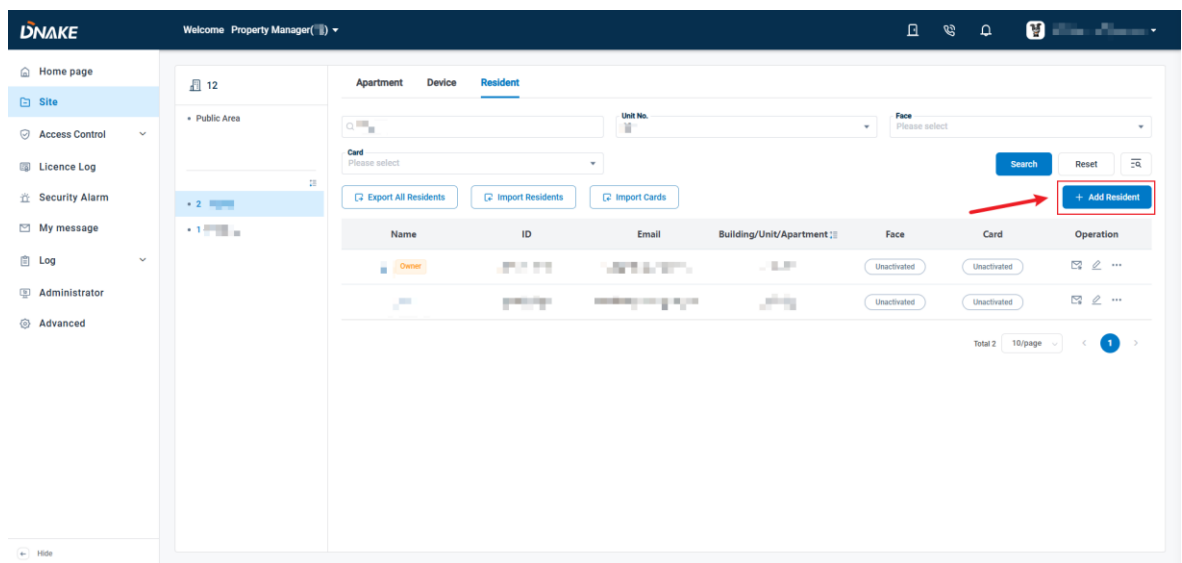

- ◆ Step 2: Select the apartment no, and enter the name, email, and Optional settings, including phone, syncing to the door station phonebook, card, and pin assignment.

← Site / New Resident

Building No. *
1 - Building ▼

Apartment No. *
Please select ▼

Name *
0/30

APP Function
 ?

Email *
0/60

Phone
(Argentina) +54 ▼ Please fill in Phone 0/16

Language *
English ▼

(Email send to users will be in language users choose)

Sync to Phonebook on door station
 ?

 [Add access credentials by the way ▼](#)

The screenshot shows a configuration form with the following elements:

- A toggle switch (checked) with a help icon.
- An **Email *** input field with a character count of 0/60.
- A **Phone** dropdown menu set to "(Argentina) +54" and a "Please fill in Phone" input field with a character count of 0/16.
- A **Language *** dropdown menu set to "English" with a note: "(Email send to users will be in language users choose)".
- A section titled "Sync to Phonebook on door station" with a toggle switch (unchecked) and a help icon.
- A blue link: "Add access credentials later ▲".
- A **Card** dropdown menu set to "Select COM" and a blue "Start Read" button.
- Three asterisked notes:
 - * Please confirm that the card reader is connected
 - * If the serial port cannot be recognized, please [download and install](#) the card reader driver.
 - * If card reading fails, please try to re-plug and unplug the serial port device.
- A "Full Card No. N" dropdown menu, a "Hexadecimal" dropdown menu, and an input field with a character count of 0/20.
- A dashed box containing a "+ Add" link.
- A **PIN Code** dropdown menu set to "APT+PIN", an "Apartment No." input field, and a character count of 0/4.
- At the bottom, "Cancel" and "Save" buttons.

Noted: Residents can upload **Face ID** on the **Smart Pro APP**.

(Reller/Installer needs to enable Register Face ID in the APP function when creating sites or editing existed one. For detailed instructions, refer to sections 5.3.1 and 5.3.2)

2. Here are the steps to import residents

- ◆ Step 1: Go to the Site column and select the desired building, then click Resident and choose Import Residents to import residents.

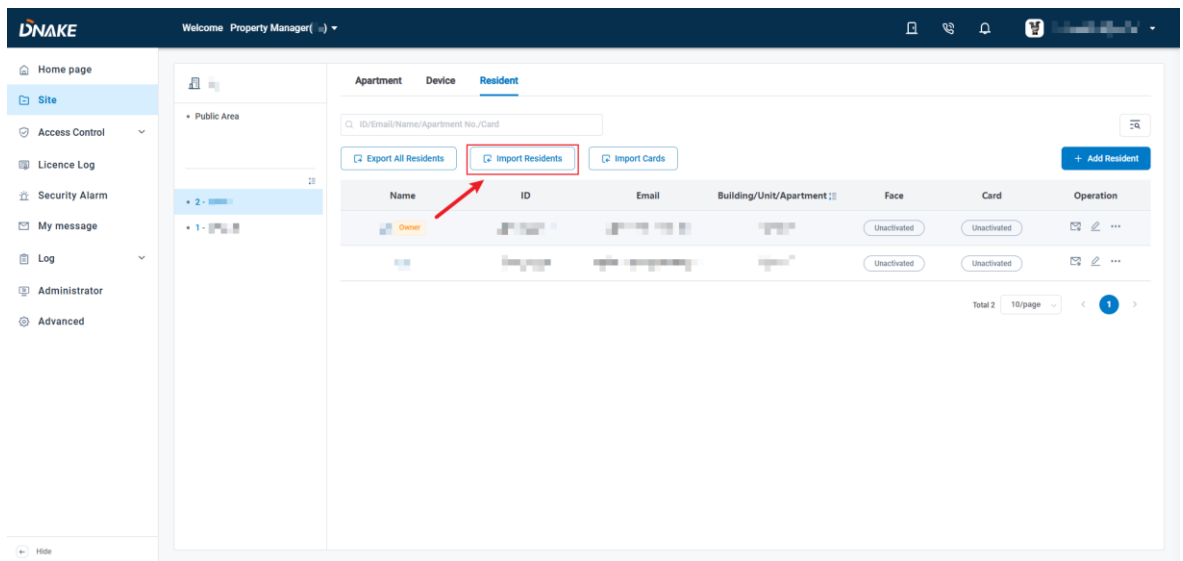

- ◆ Step 2: Click Note to view the Template Fields and click to download the template to fill in the necessary information

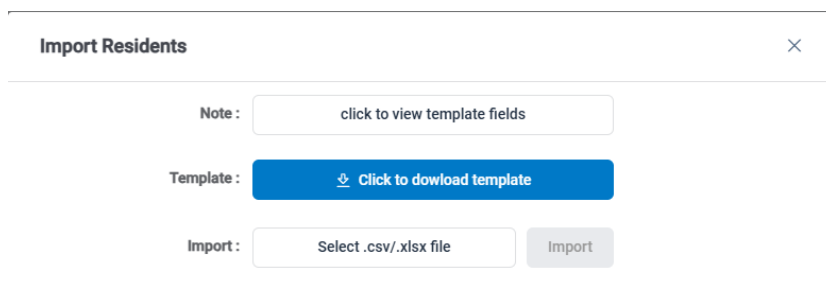

- ◆ Step 3: Click Select .csv file to upload the file and click Import to import the card information.

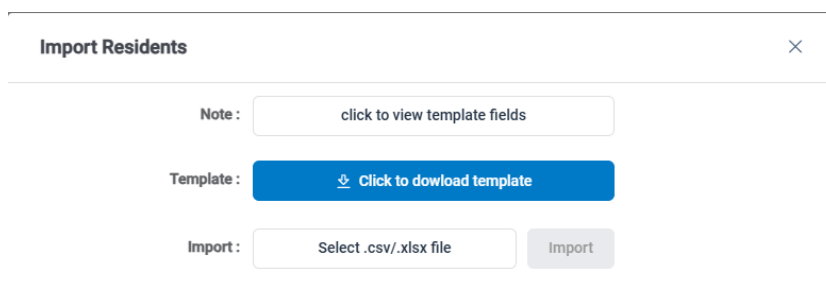

6.2.3.2 Add Cards

1. Here are the steps to add a new card for a dedicated resident

- ◆ Step 1: Go to the Site column and select the desired building, then choose Resident and click Edit to add a new card for a dedicated resident.

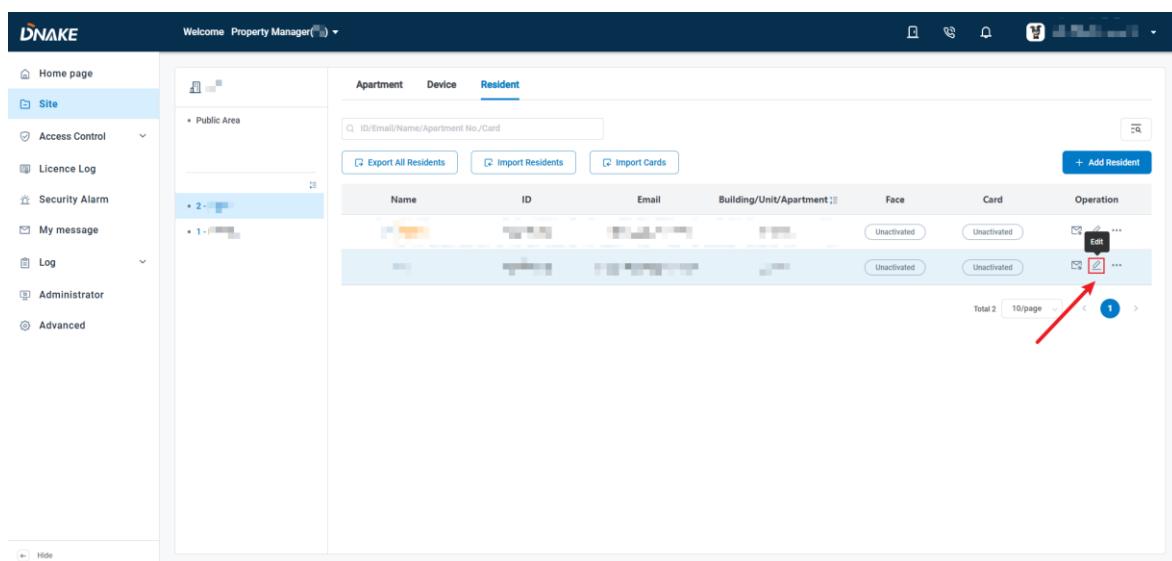

- ◆ Step 2: Select the COM port, then click Start Read (ensure the card reader is connected and drivers are installed).

Card

Select COM ▼ Start Read

* Please confirm that the card reader is connected
 * If the serial port cannot be recognized, please [download and install](#) the card reader driver.
 * If card reading fails, please try to re-plug and unplug the serial port device.

Full Card No. Mc ▼ Hexadecimal ▼ 0/20

+ Add

Noted: Compatible Mode is used when you read cards by a card reader, while Full Card No. Mode is used when you need to input the full card number.

1. Here are the steps to import cards for residents

- ◆ Step 1: Go to the Site column and select the desired building, then choose Resident and click Import Cards to import cards for residents

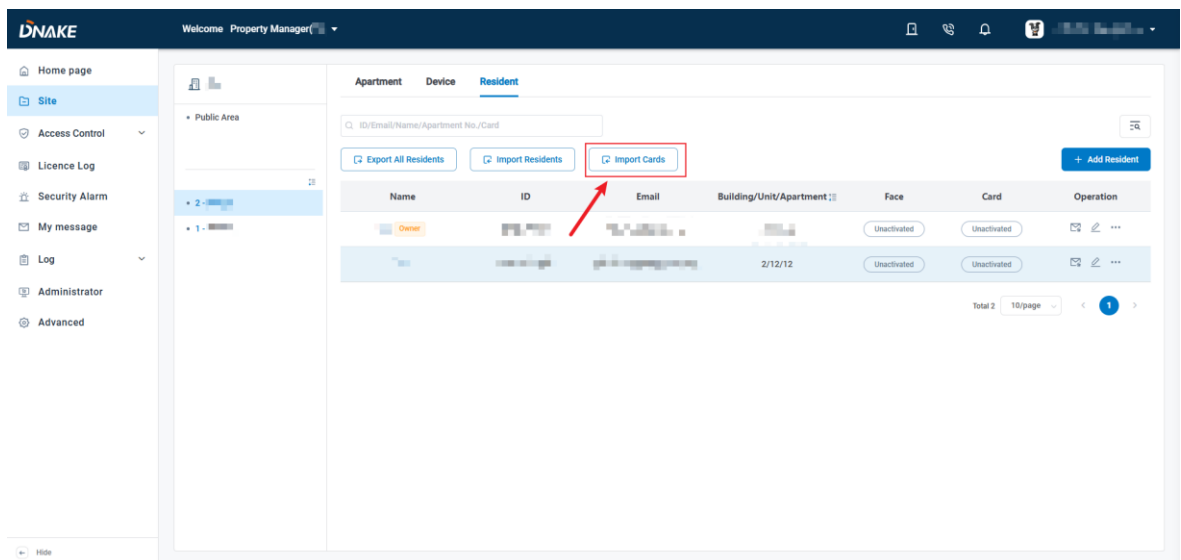

- ◆ Step 2: Click Template to download the template to fill in the necessary information

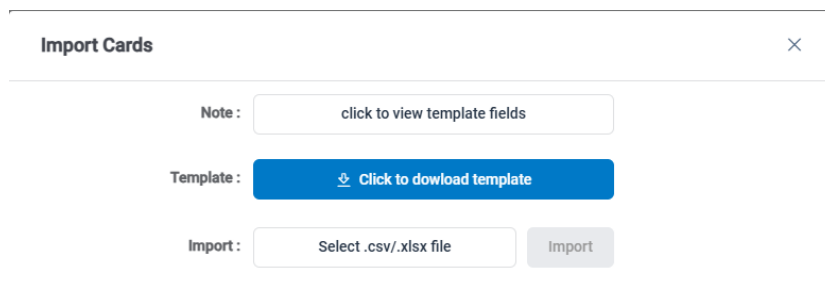

- ◆ Step 3: Click Select .csv file to upload the file and click Import to import the card information.

Import Cards ✕

Note :

Template : [Click to download template](#)

Import :

6.2.3.3 Add Pin Code

1. Here are the steps to add a new card for a dedicated resident

- ◆ Step 1: Go to the Site column and select the desired building, then choose Resident and click Edit to add a new PIN code for a dedicated resident.

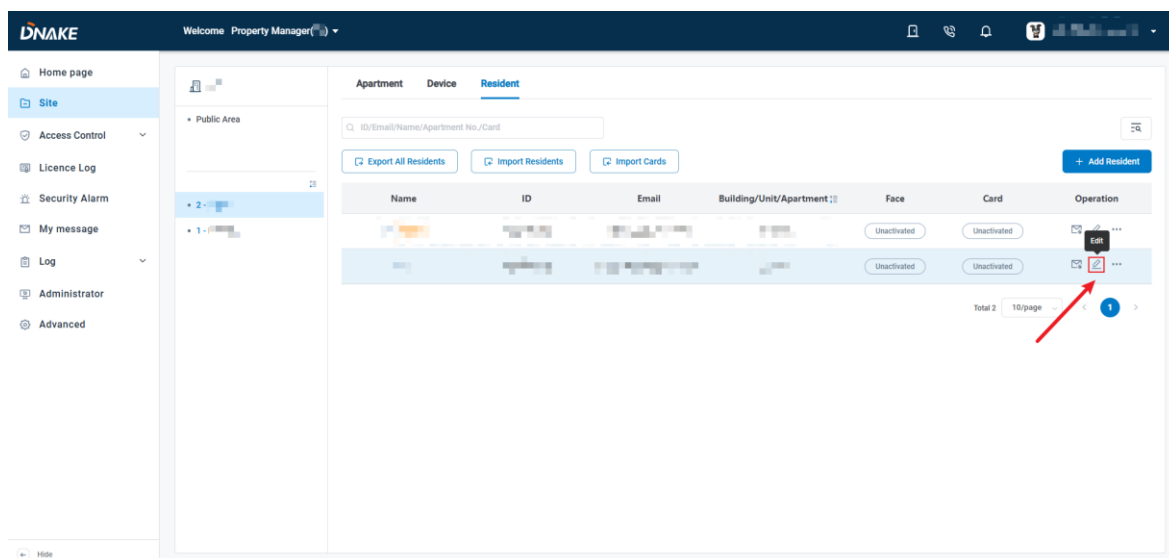

- ◆ Step 2: Select the generation mode, generate the PIN code, and click Save to save it.

APT+PIN Hexadecimal 0/20

Random + Add

PIN Code Random 0/8 Random Generation

Cancel OK

6.2.3.4 Export All Residents

- ◆ Go to the Site column and select the desired building, then choose Resident and click Export All Residents to export all residents

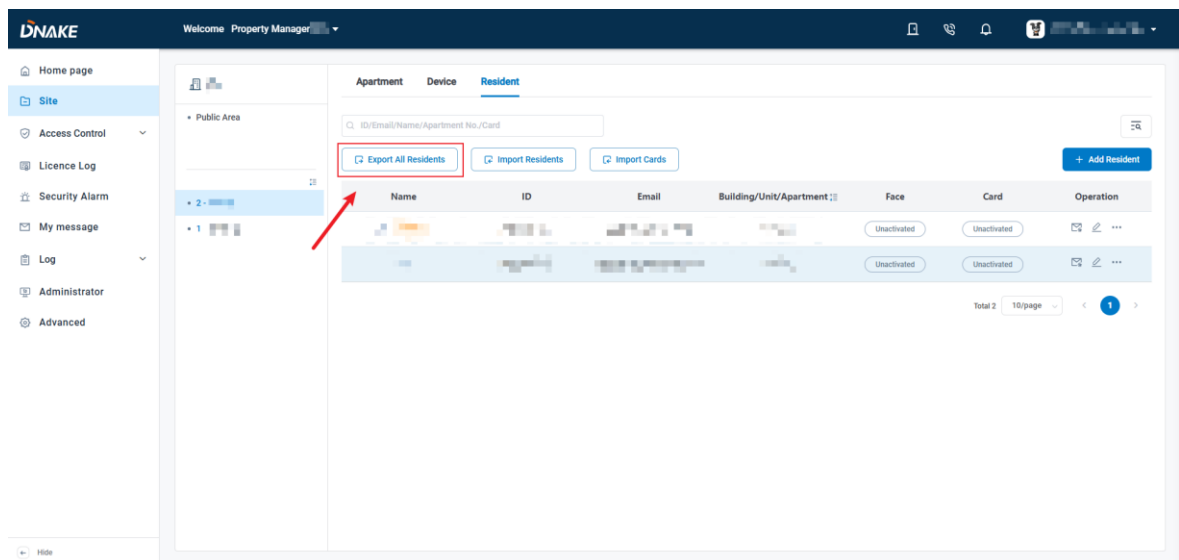

6.3 Access Control

6.3.1 Person

You can add access permissions, such as facial recognition and card access, for different roles on the cloud platform. The three roles are staff, tenant, visitor, and customized. To assign permissions, simply click Add under each role.

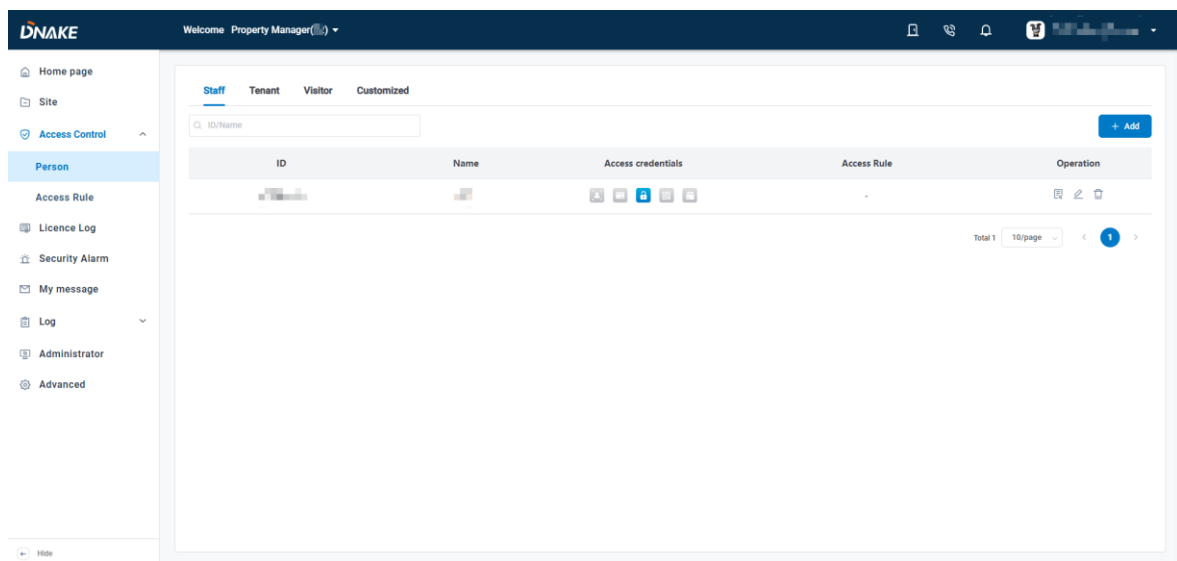

6.3.1.1 Staff

- ◆ Step 1: Enter the name and any Remarks in the information section.
- ◆ Step 2: Upload their face image, add a card by a card reader or card number, and generate a PIN code. You can choose whether to generate a QR code for unlocking.
- ◆ Step 3: Set up specific Access Rules for each staff member.

The screenshot shows the 'Person / New Staff' form in the DNAKE web interface. The form is organized into several sections:

- Information:** Contains a 'Name' field (0/30) and a 'Remarks' field (0/120).
- Access credentials:** This section is currently empty.
- Face:** Includes an 'Upload image' button and three instructions:
 - Please provide a clear headshot without a hat.
 - There can only be one face in the photo, with no obstruction and a normal expression.
 - It is recommended to use photos with a white background to increase recognition efficiency.
 - The photo format is JPG, and size should be within 512K.
- Card:** Features a 'Select COM' dropdown menu, a 'Start Read' button, and a 'Full Card N' field (0/20). It also includes instructions:
 - Please confirm that the card reader is connected.
 - If the serial port cannot be recognized, please [download and install](#) the card reader driver.
 - If card reading fails, please try to re-plug and unplug the serial port device.
- Access Rule:** Contains an '+ Add' button and a 'Total 0' indicator.

At the bottom of the form, there are 'Cancel' and 'Save' buttons. The left sidebar shows navigation options like 'Home page', 'Site', 'Access Control', 'Person', 'Access Rule', 'Licence Log', 'Security Alarm', 'My message', 'Log', 'Administrator', and 'Advanced'.

6.3.1.2 Tenant

- ◆ Step 1: Enter the name, Building/Unit/Apartment, and any information in the information section.
- ◆ Step 2: Upload their face image, add a card by a card reader or card number, and generate a PIN code. You can choose whether to generate a QR code for unlocking.

- ◆ Step 3: Set up specific Access Rules for each tenant member. Be sure to specify the validity period for these rules and choose a frequency. The available frequency options are: Never, Daily, Weekly. Additionally, assign the relevant devices to each Access Rule.

With the new **Additional Access Rule** feature, you can now associate existing **Access Rules** with the tenant instead of creating a new rule from scratch. This allows for more flexible and efficient access management.

The screenshot displays the 'Person / New Tenant' configuration page in the DNAKE system. The interface includes a top navigation bar with the DNAKE logo and user information, and a left sidebar with navigation options. The main content area is divided into several sections:

- Information:** Contains a 'Name' field (0/30), a 'Building/Unit/Apartment' section with dropdowns for 'Building No. : 1-99', 'Unit No. : 0-99', and 'Apartment No. :', an 'Email' field (0/60), and a 'Remarks' text area (0/120).
- Access credentials:** A section header for the following options.
- Face:** Includes an 'Upload image' button and a list of instructions:
 - Please provide a clear headshot without a hat.
 - There can only be one face in the photo, with no obstruction and a normal expression.
 - It is recommended to use photos with a white background to increase recognition efficiency.
 - The photo format is JPG, and size should be within 512K.
- Card:** Features a 'Select COM' dropdown, a 'Start Read' button, and instructions:
 - Please confirm that the card reader is connected.
 - If the serial port cannot be recognized, please [download and install](#) the card reader driver.
 - If card reading fails, please try to re-plug and unplug the serial port device.
 Below these are 'Full Card N' and 'Hexadecim' dropdowns, a text field (0/20), and an '+ Add' button.
- PIN Code:** Includes a 'PIN Code' field (0/8) with a 'Random Generation' button, and a checkbox for 'Generate a QR code from the PIN Code'.

At the bottom of the form are 'Cancel' and 'Save' buttons. The left sidebar has a 'Hide' button at the bottom.

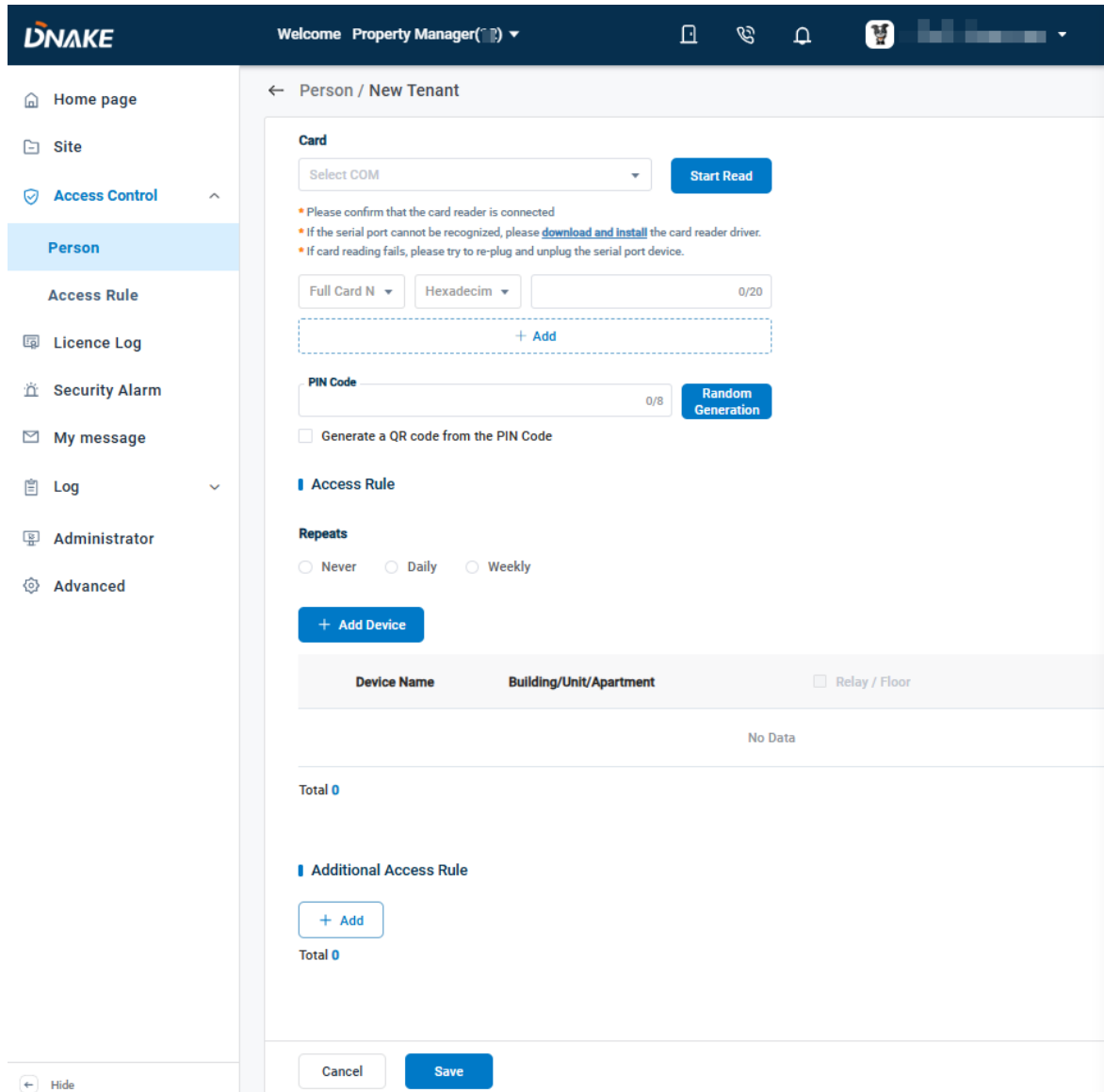

6.3.1.3 Visitor

- ◆ Step 1: Enter the name and any Remarks in the information section.
- ◆ Step 2: Upload their face image, add a card by a card reader or card number, and generate a PIN code. You can choose whether to generate a QR code for unlocking.
- ◆ Step 3: Set up specific Access Rules for each visitor member. Be sure to

specify the validity period for these rules and choose a frequency. The available frequency options are: Never, Daily, Weekly.

The screenshot displays the DNAKE web application interface. At the top, there is a dark blue header with the DNAKE logo on the left, the text 'Welcome Property Manager' followed by a dropdown arrow, and several utility icons (mobile, refresh, notifications, profile) on the right. A left sidebar contains a navigation menu with items: Home page, Site, Access Control (with a sub-menu arrow), Person (highlighted in light blue), Access Rule, Licence Log, Security Alarm, My message, Log, Administrator, and Advanced. The main content area is titled 'Person / New Visitor' and contains the following form sections:

- Information:** A text input field for 'Name' (0/30 characters) and a larger text area for 'Remarks' (0/120 characters).
- Access credentials:**
 - Face:** An 'Upload image' button with a camera icon. Below it are three bullet points: 'Please provide a clear headshot without a hat.', 'There can only be one face in the photo, with no obstruction and a normal expression.', and 'It is recommended to use photos with a white background to increase recognition efficiency.' A note states 'The photo format is JPG, and size should be within 512K.'
 - Card:** A 'Select COM' dropdown menu and a 'Start Read' button. Below are three bullet points: 'Please confirm that the card reader is connected', 'If the serial port cannot be recognized, please download and install the card reader driver.', and 'If card reading fails, please try to re-plug and unplug the serial port device.' There are also 'Full Card N' and 'Hexadecim' dropdowns, and a text input field (0/20 characters) with a '+ Add' button below it.
- PIN Code:** A text input field (0/8 characters) and a 'Random Generation' button. Below it is a checkbox labeled 'Generate a QR code from the PIN Code'.

At the bottom of the form are 'Cancel' and 'Save' buttons. A 'Hide' button is visible at the bottom left of the sidebar area.

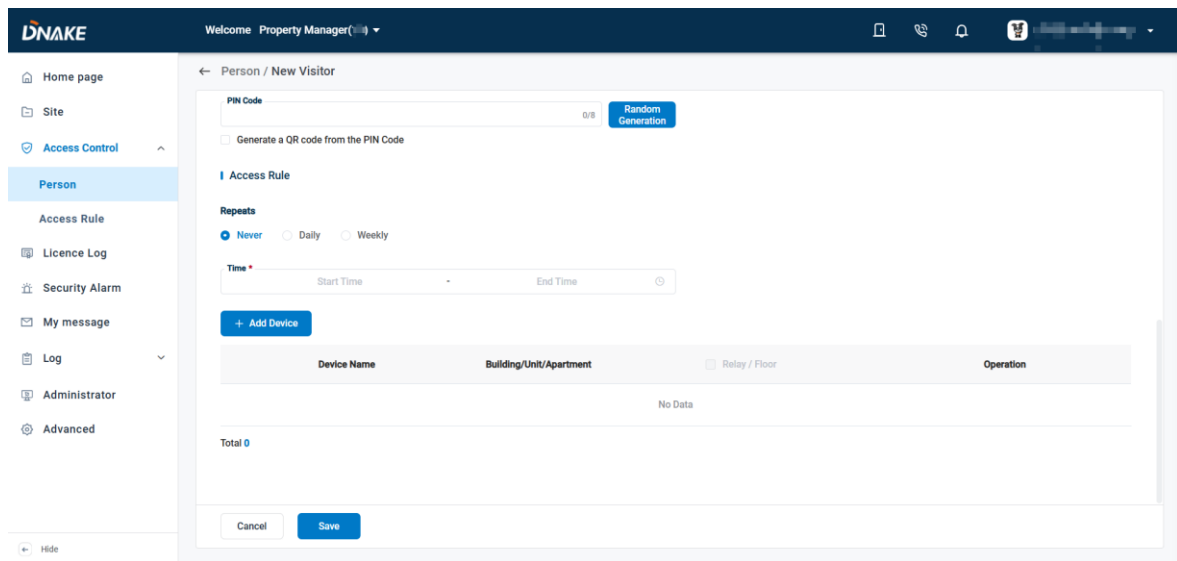

6.3.1.4 Customized

- ◆ Step 1: Enter the name and any Remarks in the information section.
- ◆ Step 2: Upload their face image, add a card by a card reader or card number, and generate a PIN code. You can choose whether to generate a QR code for unlocking.
- ◆ Step 3: Set up specific Access Rules for each staff member.

The screenshot shows the 'Person / New Customized' configuration page in the DNAKE web interface. The page is divided into several sections:

- Information:** Includes a 'Name' field (0/30) and a 'Remarks' field (0/120).
- Access credentials:** Contains a 'Face' section with an 'Upload image' button and instructions:
 - Please provide a clear headshot without a hat.
 - There can only be one face in the photo, with no obstruction and a normal expression.
 - It is recommended to use photos with a white background to increase recognition efficiency.
 - The photo format is .JPG, and size should be within 512K.
- Card:** Features a 'Select COM' dropdown, a 'Start Read' button, and instructions:
 - Please confirm that the card reader is connected.
 - If the serial port cannot be recognized, please [download and install](#) the card reader driver.
 - If card reading fails, please try to re-plug and unplug the serial port device.
 Below this is a 'Full Card N' dropdown, a 'Hexadecim' dropdown, and a text field (0/20) with a '+ Add' button.
- PIN Code:** Includes a PIN Code field (0/8), a 'Random Generation' button, and a checkbox for 'Generate a QR code from the PIN Code'.
- Access Rule:** Contains a '+ Add' button and a 'Total 0' indicator.

At the bottom of the page, there are 'Cancel' and 'Save' buttons.

6.3.2 Access Rule

The Access Rule Type provides two options: Normal and Free Access. The Normal rule is used to control access by defining which users are allowed to unlock specific doors within designated time periods, while the Free Access rule allows all users to unlock the specified doors freely during the configured time

periods.

You can create custom Access Rules that can be applied to Staff, Tenants, Visitors, and Customized.

6.3.2.1 Normal

Here are the steps to configure a normal access rule

- ◆ Step 1: Go to the Access Control column and choose Access Rule, then click Create to add an access rule.

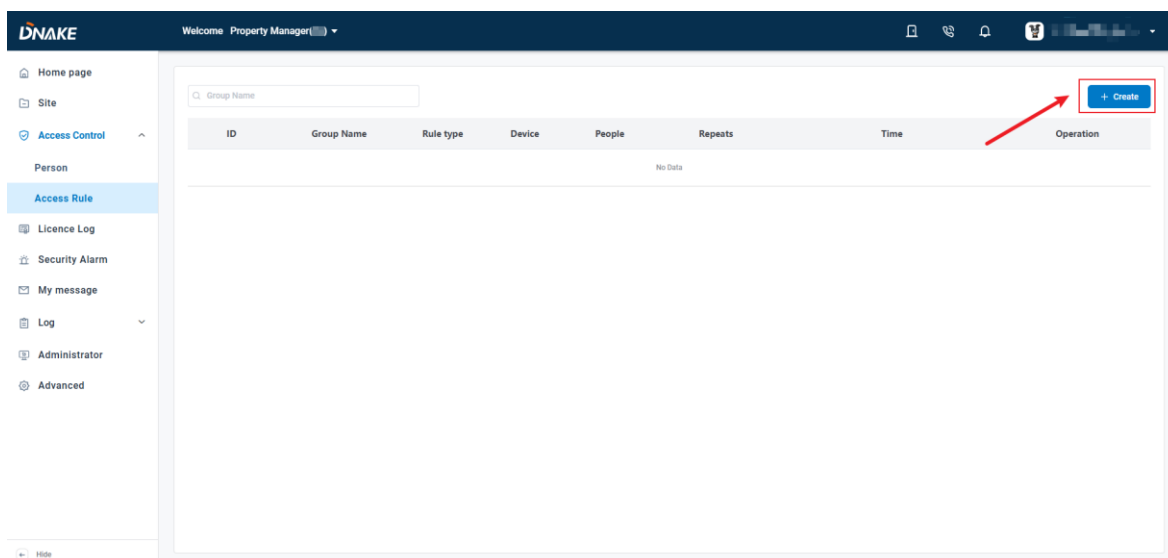

- ◆ Step 2: Fill in the group name, select the repeat option (Never, Daily, or Weekly), set the validity period, and link the specified devices and people to the access rule. (Rule type is normal by default)

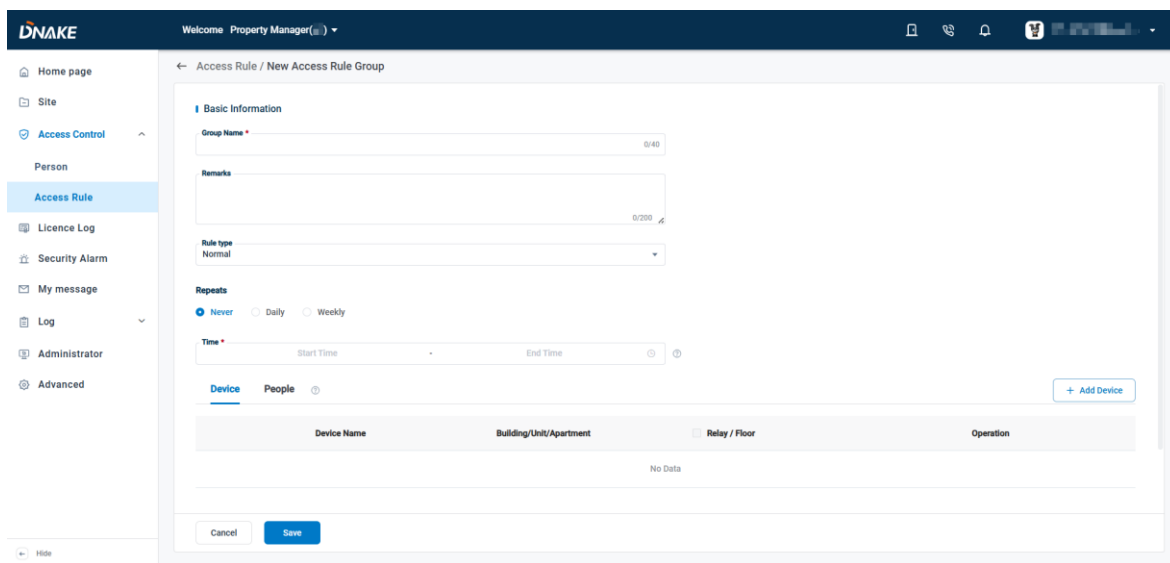

6.3.2.2 Free Access

Here are the steps to configure a free access rule

- ◆ Step 1: Go to the Access Control column and choose Access Rule, then click Create to add an access rule.

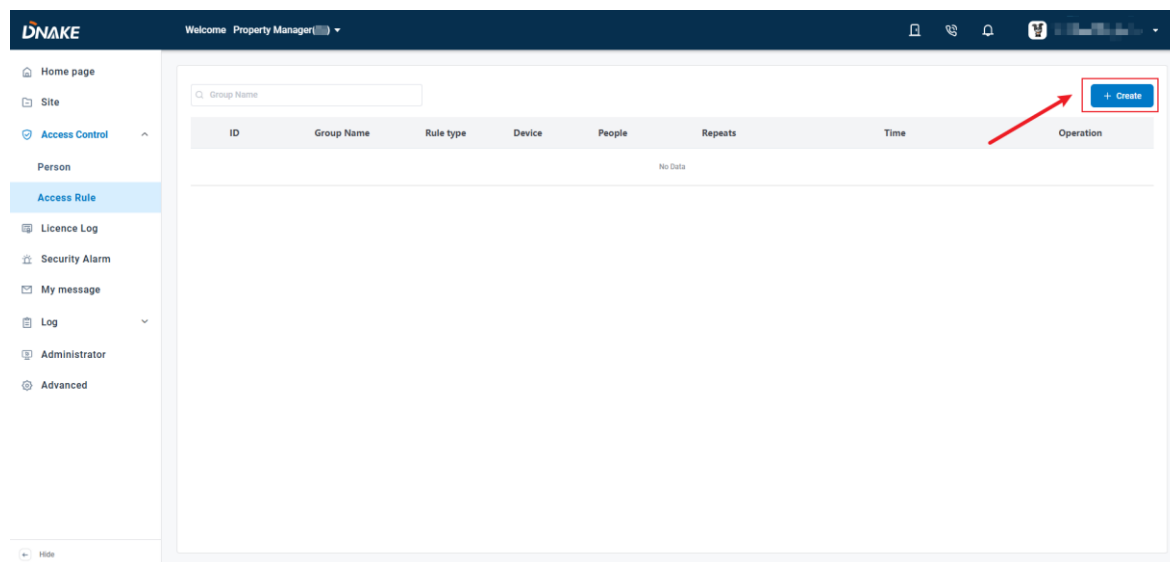

- ◆ Step 2: Fill in the group name, select the repeat option (Never, Daily, or Weekly), select the free access, set the validity period, and link the specified

devices to the access rule.

New Access Rule Group Access Rule / New Access Rule Group

Basic Information

Group Name * 0/40

Remarks 0/200

Rule type

Repeats

Never Daily Weekly

Time * - ⌚ ⌚

Device ⓘ [+ Add Device](#)

Device Name	Building/Unit/Apartment	<input type="checkbox"/> Relay	Operation
No Data			

6.3.3 Delivery Passcode

The cloud platform allows you to create a Delivery Code for couriers. When the courier arrives, they enter the Delivery Code, select the resident, and input the number of packages. The corresponding resident will then receive a package notification in their app. (It only supports S617 right now and will support more devices in the future.)

- ◆ Step 1: Go to the Site column and select the desired community, then click the desired building and choose Device. Then edit S617 to enable the “Delivery”.

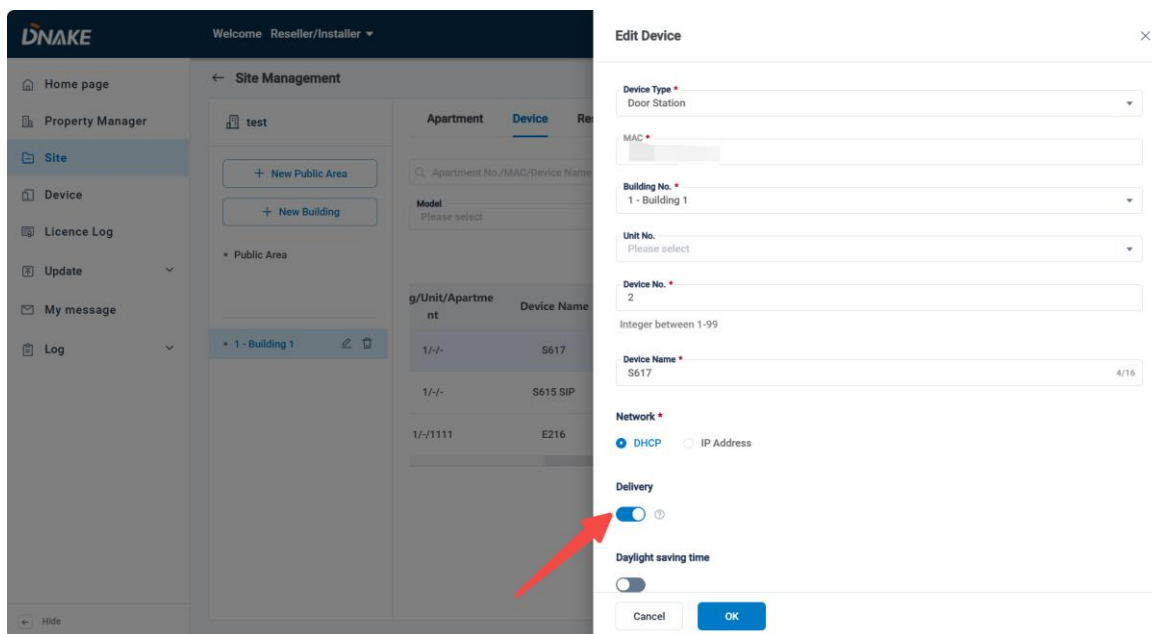

- ◆ Step 2: Go to the community under the property manager, click Access Control>Person, click Delivery, and then Add to add a delivery code for couriers.

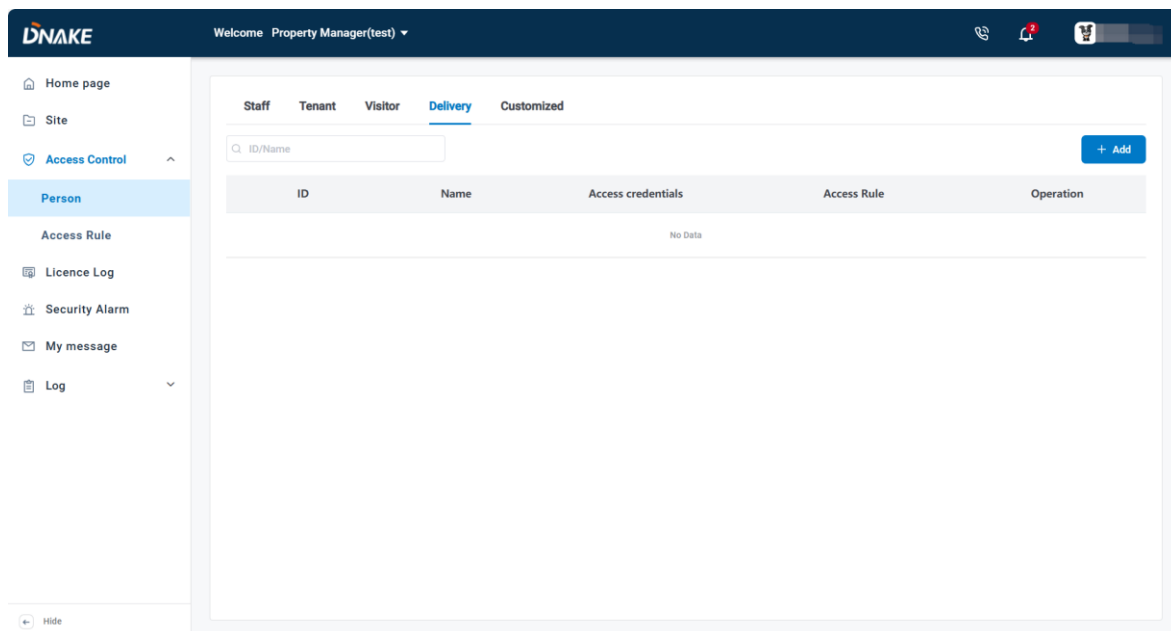

- ◆ Step 3: Enter a Delivery Name and generate a Delivery Code for the courier. Then, assign the relevant Access Rule to this delivery.

The screenshot shows the DNAKE web interface. The top navigation bar includes the DNAKE logo, a welcome message for 'Property Manager(test)', and user profile information. A left sidebar contains navigation options: Home page, Site, Access Control, Person (highlighted), Access Rule, Licence Log, Security Alarm, My message, and Log. The main content area is titled 'New Delivery' and contains the following form fields:

- Information**
 - Name: Text input field with a character count of 0/30.
 - Remarks: Text area with a character count of 0/120.
- Access credentials**
 - Delivery Code: Text input field with a character count of 0/8 and a 'Random Generation' button.
- Access Rule**
 - + Add button.
 - Total 0.

At the bottom of the form are 'Cancel' and 'Save' buttons.

◆ Step 4: Go to the device, then click Delivery

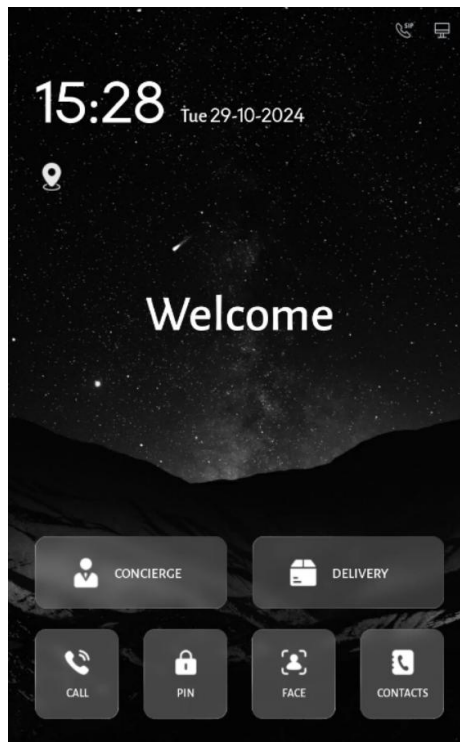

◆ Step 5: Enter the delivery code.

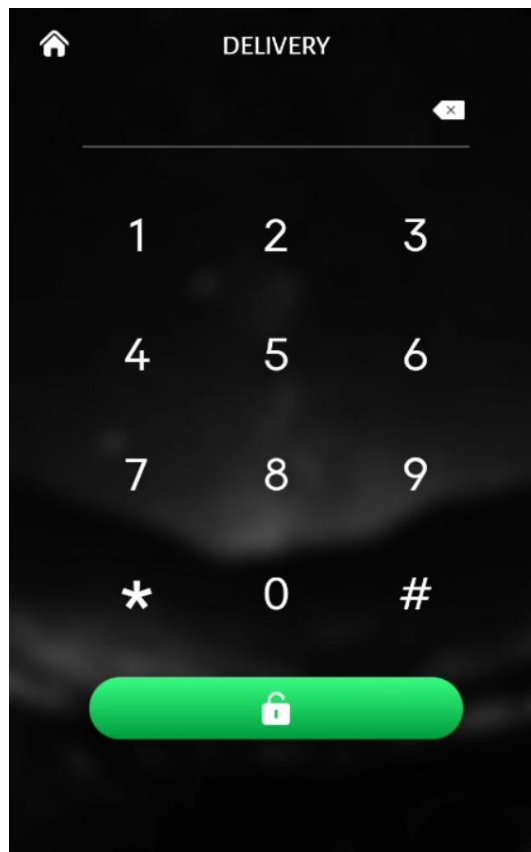

- ◆ Step 6: Send a message to notify the resident that their package has arrived.
The notification will appear in Smart Pro.

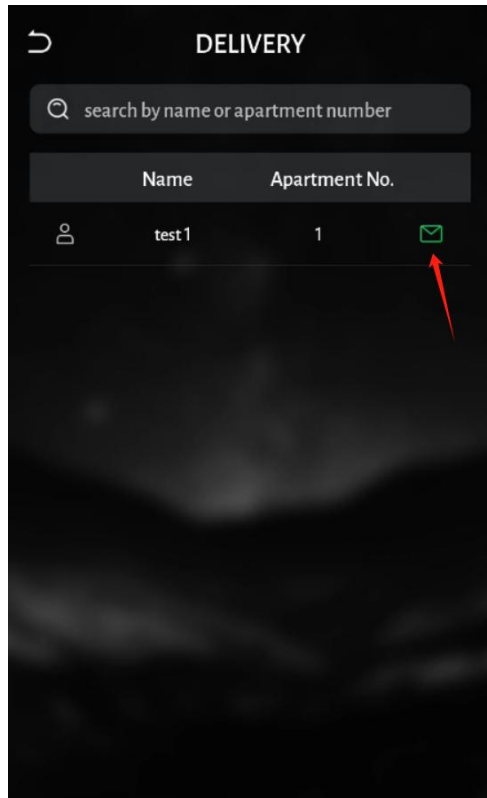

6.4 License Log

1. You can check the number of licenses you have and the license log.

Item	Time	Type	Operation	Amount	Source/Destination	Holdings	Remarks
1	2026-03-16 16:25:06	With Indoor Monitor	Room Use	-1	2/12/12	0	-
2	2026-03-16 16:24:54	Value-added Services	Issued By Superior	+1	D Test	2	-
3	2026-03-16 16:24:54	With Indoor Monitor	Issued By Superior	+1	D Test	1	-
4	2026-03-16 16:24:54	Without Indoor Monitor	Issued By Superior	+1	D Test	2	-
5	2026-03-16 14:14:21	With Indoor Monitor	Room Use	-1	1/1/1	0	-
6	2026-03-16 14:14:08	Value-added Services	Issued By Superior	+1	D Test	1	-
7	2026-03-16 14:14:08	With Indoor Monitor	Issued By Superior	+1	D Test	1	-
8	2026-03-16 14:14:08	Without Indoor Monitor	Issued By Superior	+1	D Test	1	-

6.5 Security Alarm

1. You can receive security alarms sent from this community's Indoor Monitors. You can view the records for recent one month.

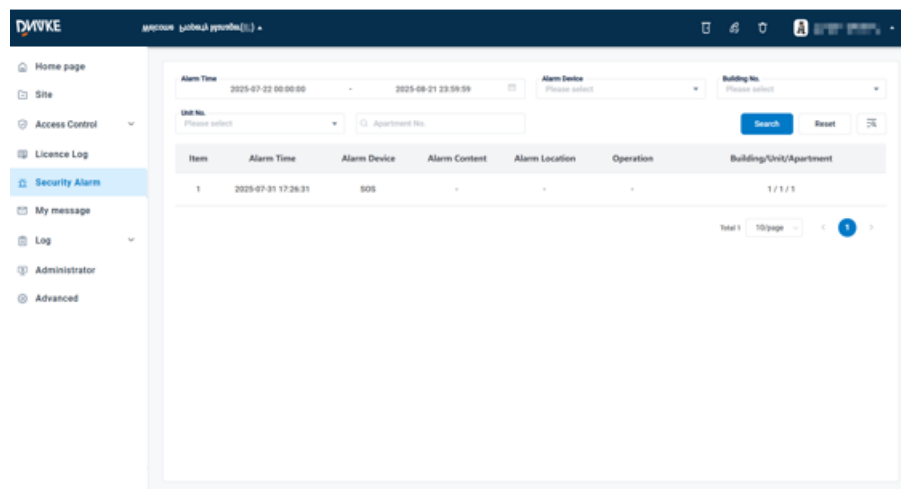

6.6 My Message

6.6.1 Send Messages to Resident

1. Here are the steps to send messages to the resident

- ◆ Step 1: Go to the My message column and click Add to edit a message.

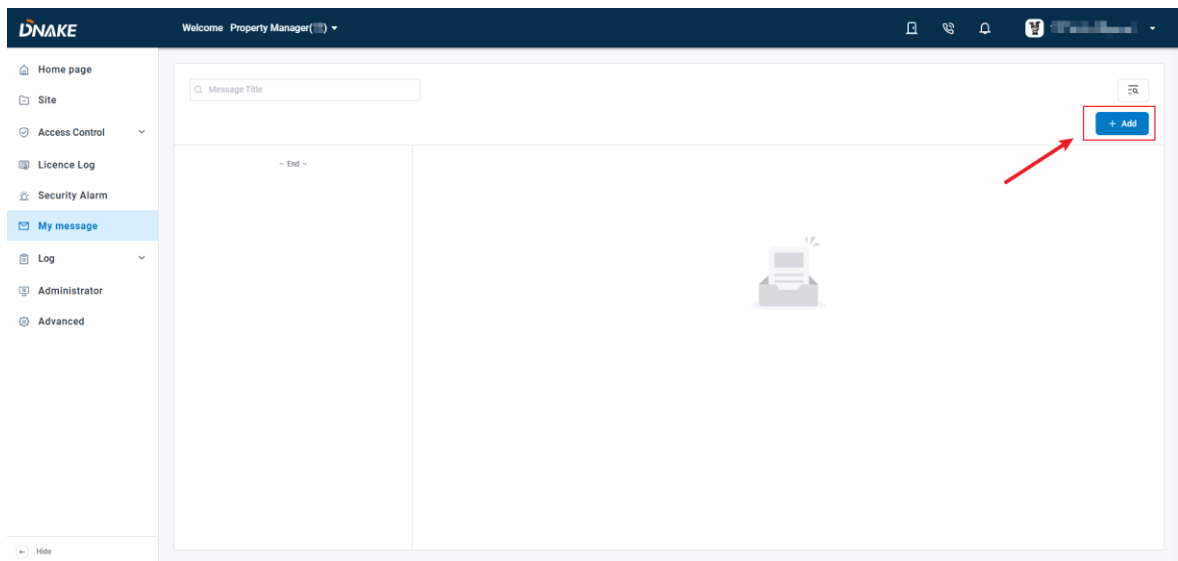

- ◆ Step 2: Fill in the message title and message content. Choose the recipient and the delivery time.

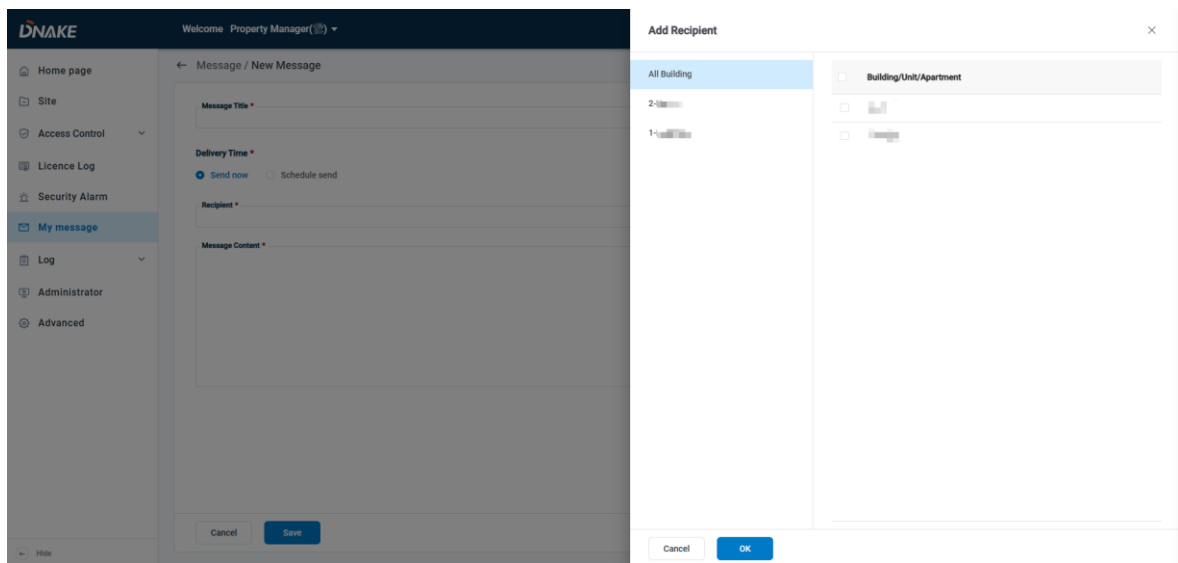

- ◆ Step 3: Click the message. You can check the message details.

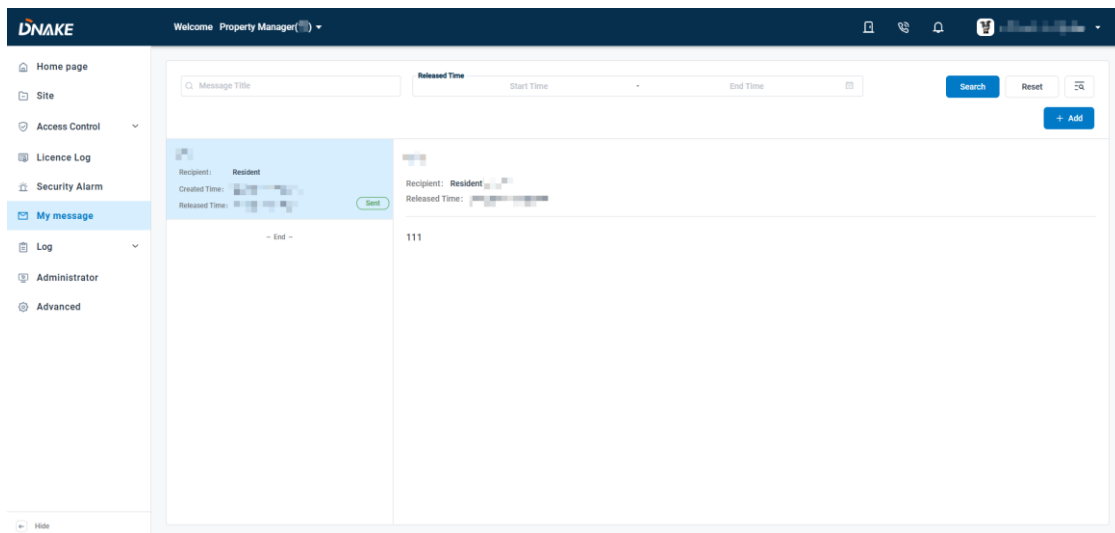

6.7 Log

6.7.1 Call Log

1. You can check the call logs of this community's devices. You can view the records for recent one month.

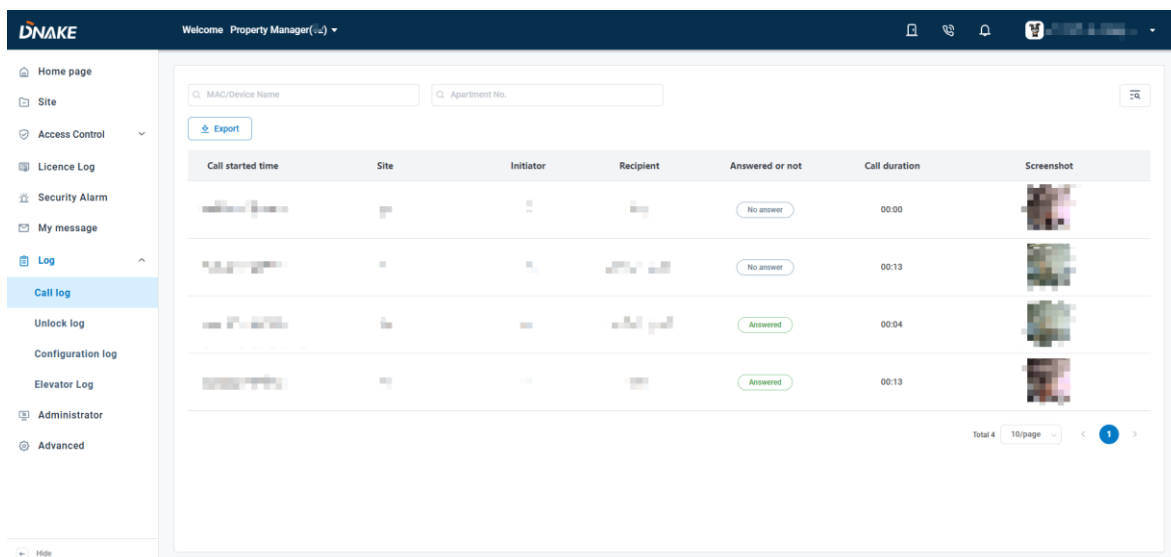

6.7.2 Unlock Log

1. You can check the unlock logs of this community's devices. You can view the

records for recent one month.

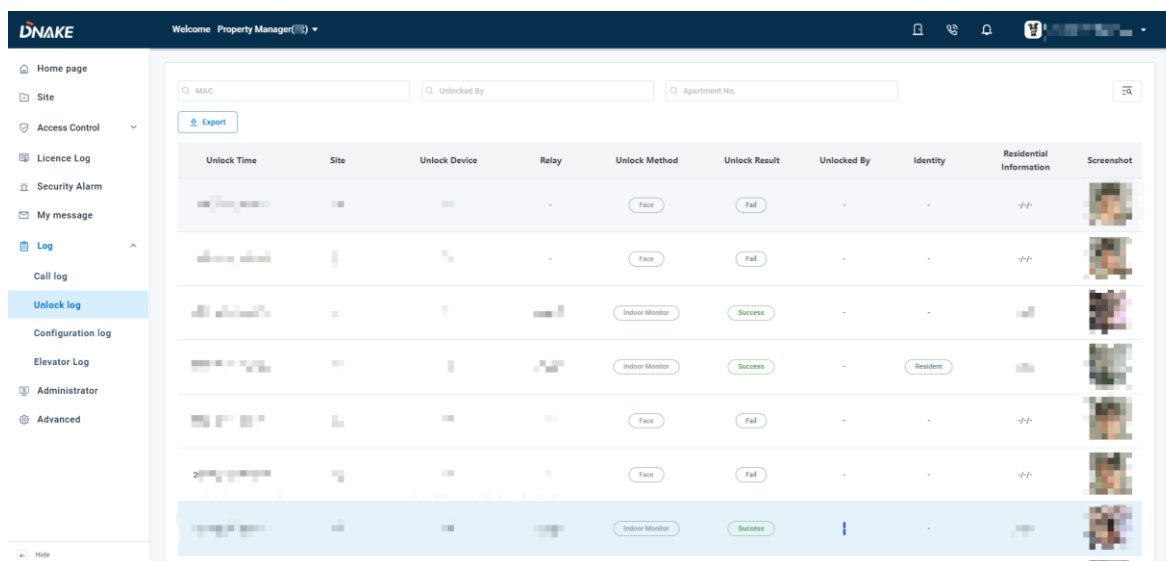

6.7.3 Configuration Log

1. You can check the configuration logs of this community's devices. You can view the records for recent one month.

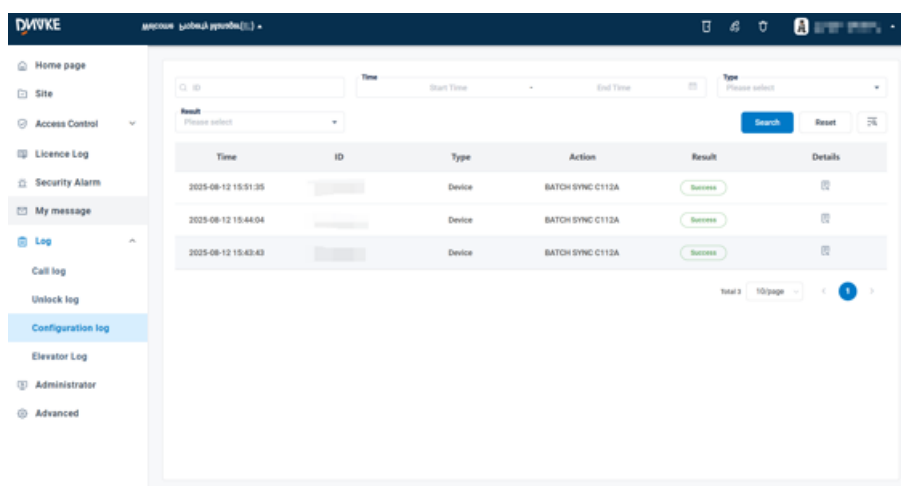

6.7.4 Elevator Log

1. You can check the elevator log if you have installed the DNAKE Elevator

Control Module. You can view the records for recent one month.

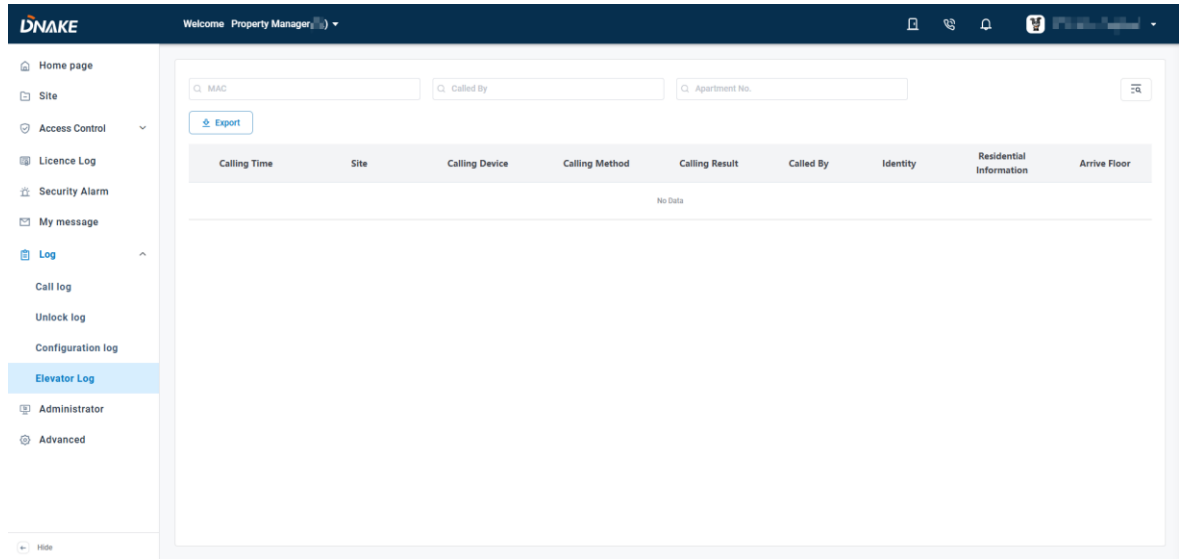

6.8 Administrator

6.8.1 Add New Administrator

- ◆ Step 1: By clicking the Add button, you can create a new administrator account.

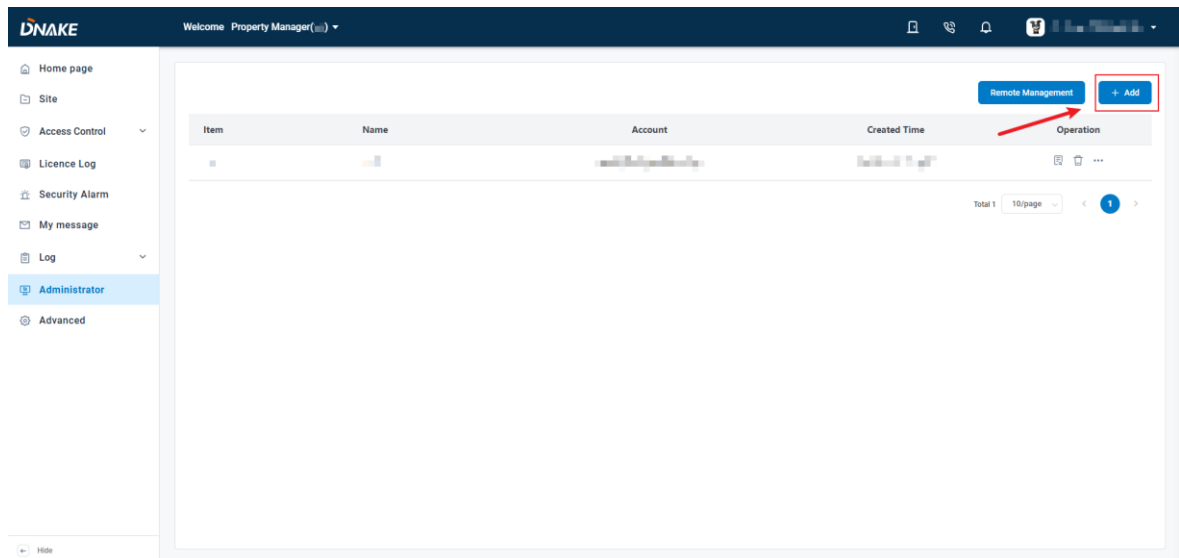

- ◆ Step 2: Enter the required information, such as Name and Email. You can also configure the administrator’s permissions, including building permissions and Management Permissions.

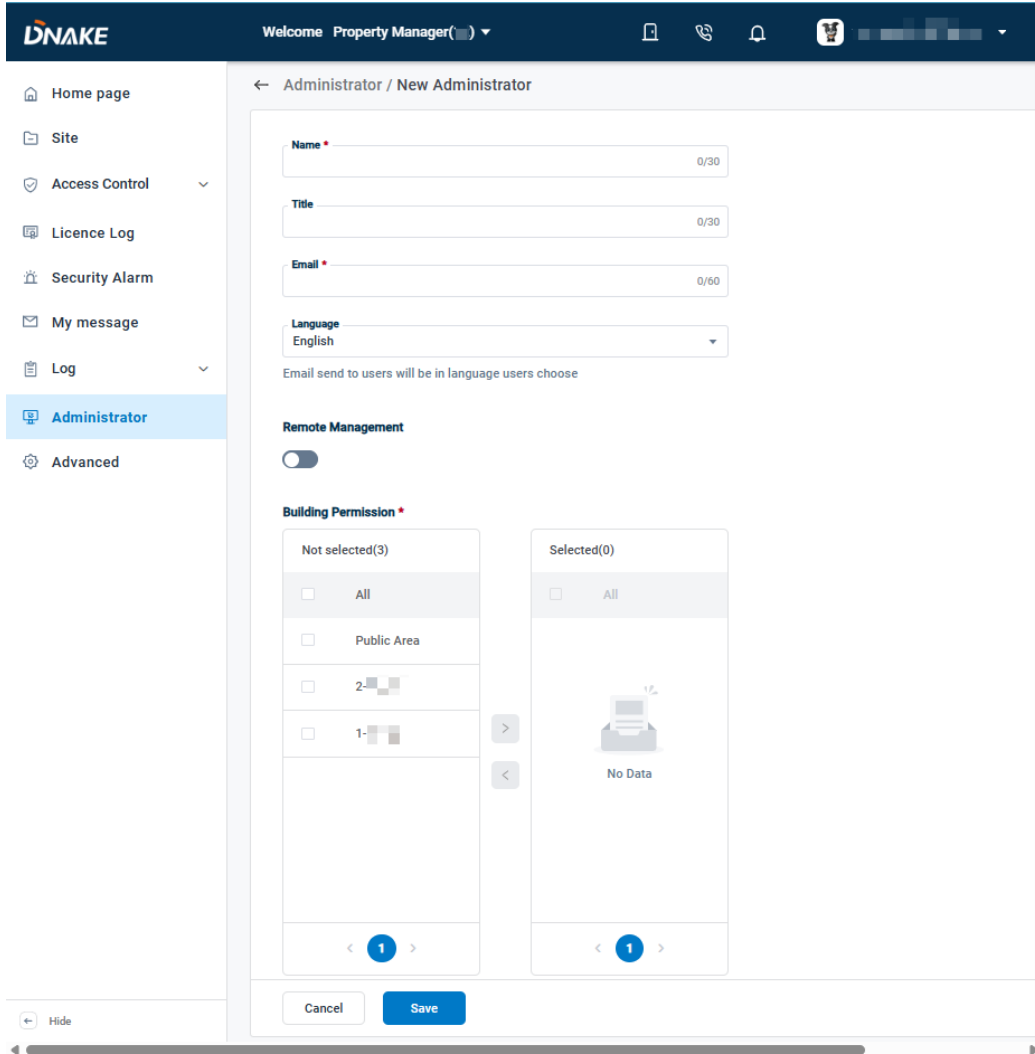

Management Permission

Features	Management Permission	
Apartment	<input type="radio"/> Read	<input type="radio"/> Read&write
Device	<input type="radio"/> Read	<input type="radio"/> Read&write
Resident	<input type="radio"/> Read	<input type="radio"/> Read&write
Access Control	<input type="radio"/> Read	<input type="radio"/> Read&write
Security Alarm	<input type="radio"/> Read	<input type="radio"/> Read&write
Message	<input type="radio"/> Read	<input type="radio"/> Read&write
Log	<input type="radio"/> Read	<input type="radio"/> Read&write

6.8.2 Remote Management

Enables property managers to use the Smart Pro, ensuring they stay connected while on patrol. With this functionality, security personnel no longer need to worry about missing calls. This enhances communication and allows property managers to provide better services to residents.

- ◆ Step 1: Log in to the installer account, go to the Site column, navigate to the desired site, and click Edit to enable Remote Management.

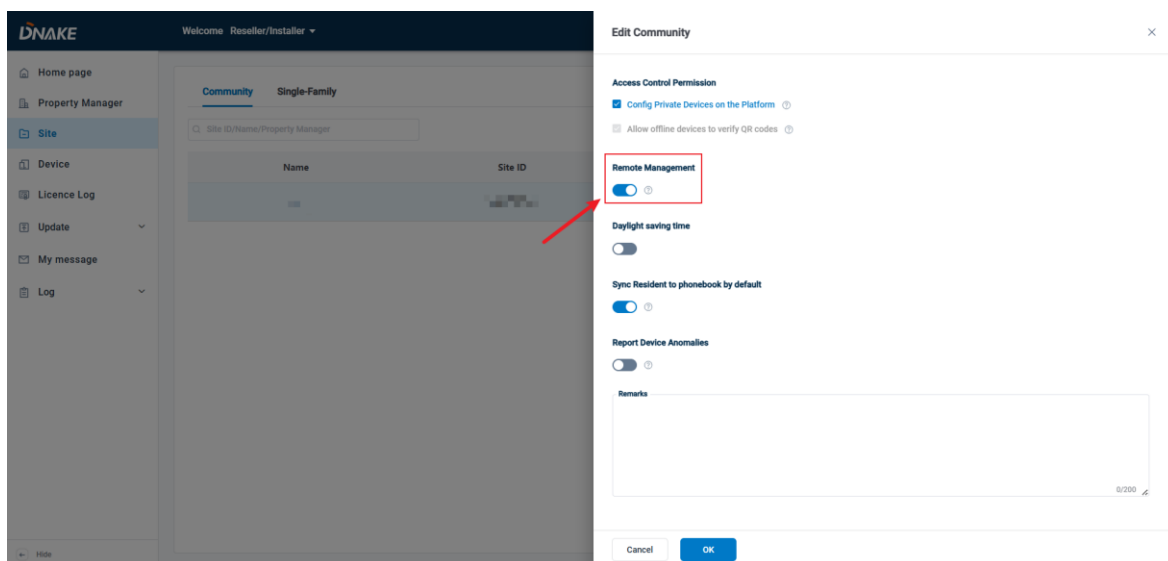

- ◆ Step 2: Log in to the Property Manager account, navigate to the Administrator section, and click Remote Management to manage the Remote Management function.

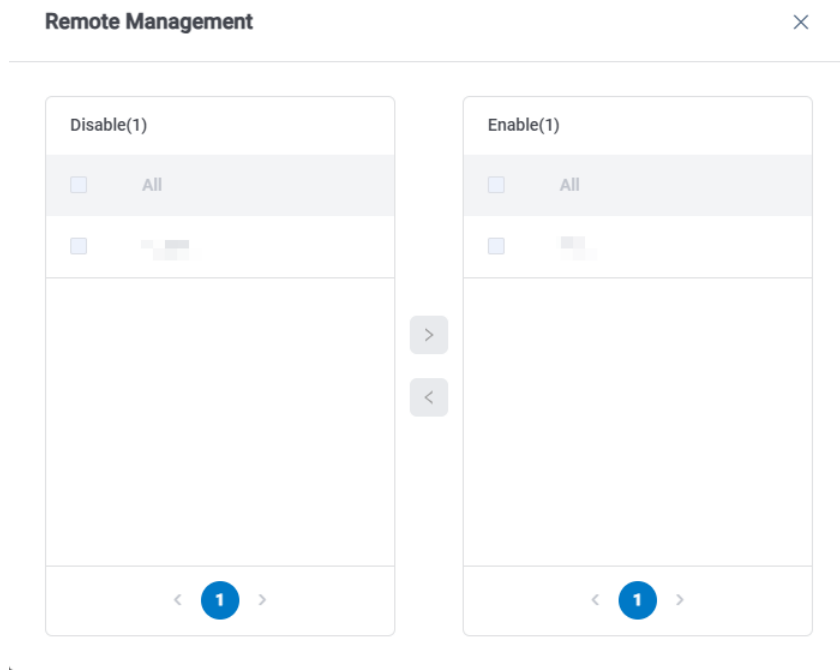
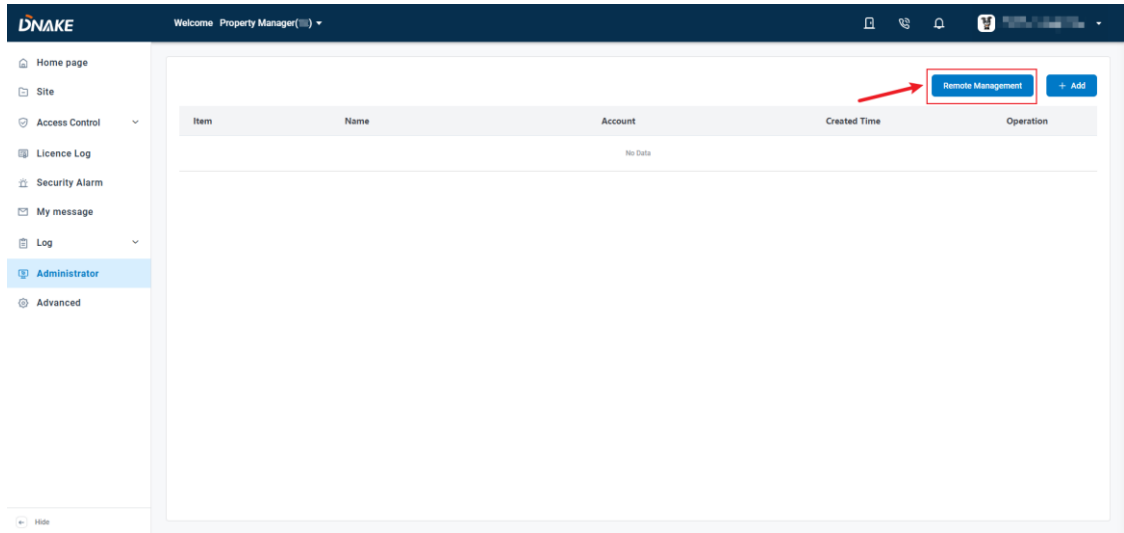

Noted: A valid license is required to activate this feature.

6.9 Advanced

6.9.1 Verification Method

In this section, you can modify the Card Mode and Card Display Mode.

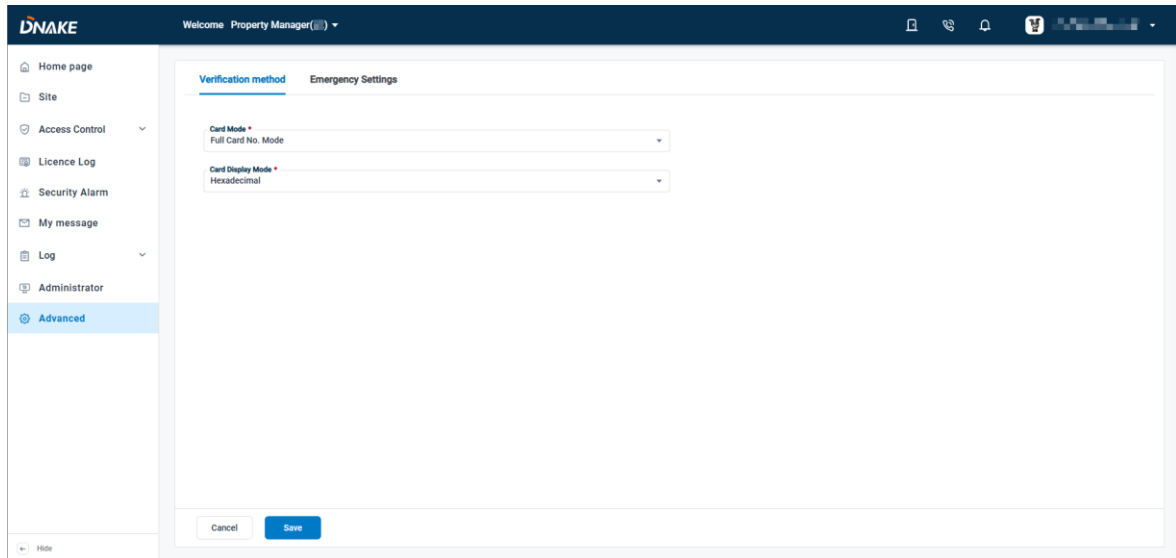

6.9.2 Emergency Setting

1. Property Manager can configure Emergency Door groups, including adding or disabling the associated relays. The Property Manager can also set up notifications sent to residents when the Emergency Door is activated and edit the notification message content.

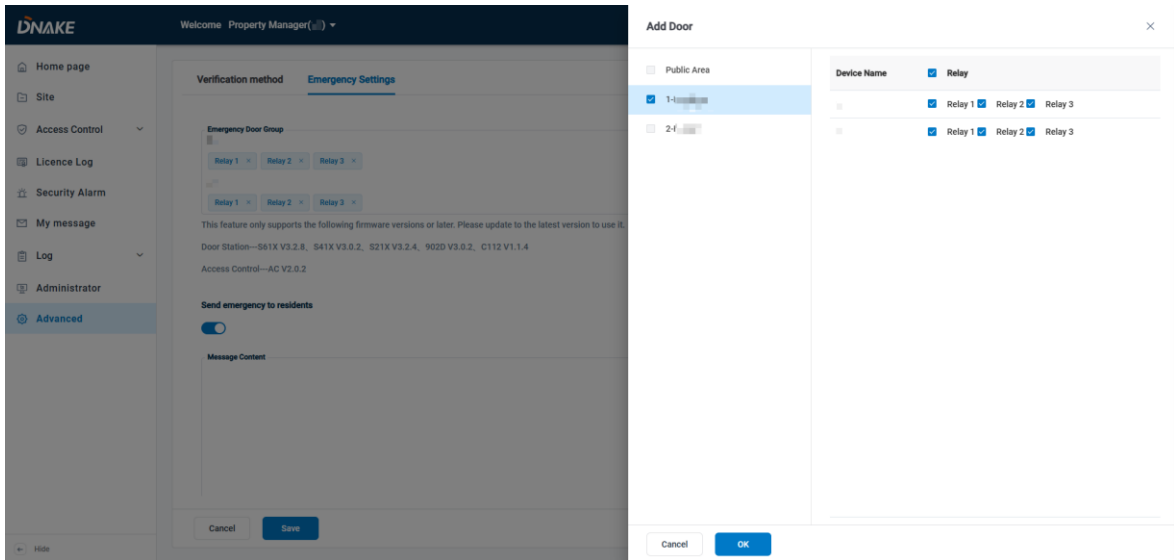

2. When an emergency occurs, the Property Manager can open or close the Emergency Escape Device function by clicking the button at the top of the page.

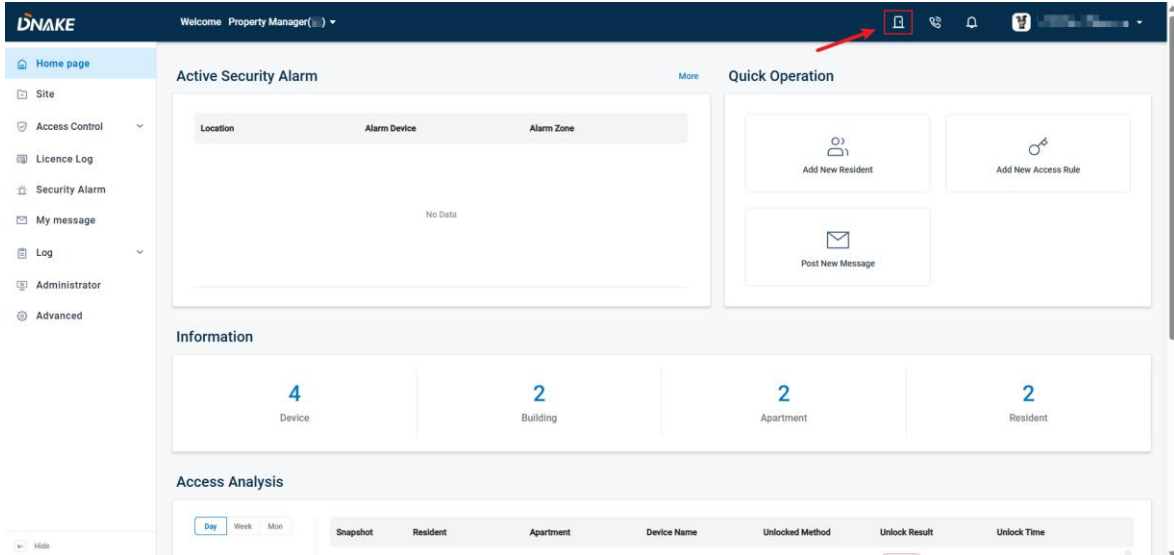

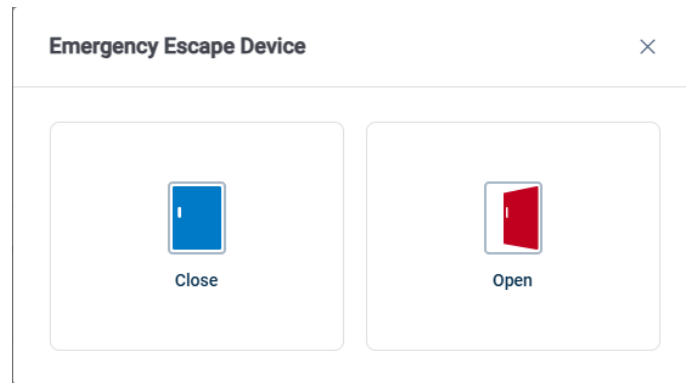

Noted: A valid license is required to activate this feature.

6.10 Contact Technical Support

1. The Property Manager can click Contact Installer to check the information about the technical support. Please make sure your Reseller/Installer has set it up before.

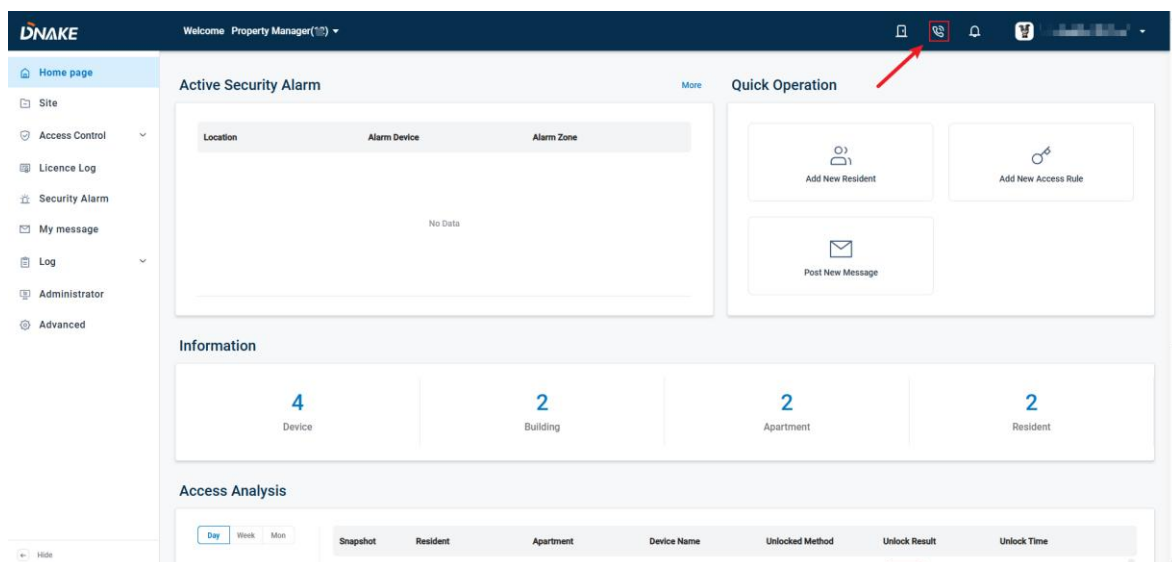

7. Appendix A:

American data center: (<https://us-cloud.dnake.com>)

Country code	Country or region	Country code	Country or region
1	United States	95	Myanmar
1	Canada	239	São Tomé e Príncipe
51	Peru	245	Guinea-Bissau
52	Mexico	246	British Indian Ocean Territory
54	Argentina	500	Falkland Islands
55	Brazil	502	Guatemala
56	Chile	591	Bolivia
57	Colombia	593	Ecuador
58	Venezuela	594	French Guiana
60	Malaysia	595	Paraguay
62	Indonesia	597	Suriname
63	Philippines	598	Uruguay
64	New Zealand	670	Timor-Leste
66	Thailand	672	Norfolk Island
81	Japan	674	Nauru
82	Republic of Korea	675	Papua New Guinea
84	Vietnam	677	Solomon Islands
1	United States	95	Myanmar
1	Canada	239	São Tomé e Príncipe
51	Peru	245	Guinea-Bissau
52	Mexico	246	British Indian Ocean Territory
54	Argentina	500	Falkland Islands
55	Brazil	502	Guatemala
56	Chile	591	Bolivia
57	Colombia	593	Ecuador
58	Venezuela	594	French Guiana

European data center: (<https://eu-cloud.dnake.com>)

Country code	Country or region	Country code	Country or region
7	Russia	241	Gabon
20	Egypt	242	Congo
27	South Africa	243	Congo (DRC)
30	Greece	244	Angola
31	Netherlands	248	Seychelles
32	Belgium	250	Rwanda
33	France	251	Ethiopia
34	Spain	252	Somalia
36	Hungary	253	Djibouti
39	Italy	254	Kenya
40	Romania	255	Tanzania
41	Switzerland	256	Uganda
43	Austria	257	Burundi
44	United Kingdom	258	Mozambique
45	Denmark	260	Zambia
46	Sweden	261	Madagascar
47	Norway	262	Mayotte
48	Poland	263	Zimbabwe
49	Germany	264	Namibia
61	Australia	265	Malawi
65	Singapore	266	Lesotho
90	Turkey	267	Botswana
92	Pakistan	268	Swaziland
93	Afghanistan	269	Comoros
94	Sri Lanka	291	Eritrea
212	Morocco	297	Aruba
213	Algeria	298	Faroe Islands
216	Tunisia	299	Greenland
218	Libya	350	Gibraltar
220	The Gambia	351	Portugal
221	Senegal	352	Luxembourg
222	Mauritania	353	Ireland
223	Mali	354	Iceland
224	Guinea	355	Albania
225	Côte d'Ivoire	356	Malta
226	Burkina Faso	357	Cyprus
227	Niger	358	Finland
228	Togo	359	Bulgaria
229	Benin	370	Lithuania
230	Mauritius	371	Latvia
231	Liberia	372	Estonia
232	Sierra Leone	373	Moldova
233	Ghana	374	Armenia
234	Nigeria	375	Belarus
235	Chad	376	Andorra
236	Central African Republic	377	Monaco

237	Cameroon	378	San Marino
238	Cabo Verde	379	Vatican City
240	Equatorial Guinea	380	Ukraine
381	Serbia	995	Georgia
382	Montenegro	996	Kyrgyzstan
385	Croatia	998	Uzbekistan
386	Slovenia	1242	Bahamas
387	Bosnia and Herzegovina	1246	Barbados
389	Macedonian	1264	Anguilla
420	Czech Republic	1268	Antigua and Barbuda
421	Slovakia	1284	British Virgin Islands
423	Liechtenstein	1340	U.S. Virgin Islands
501	Belize	1345	Cayman Islands
503	El Salvador	1441	Bermuda
504	Honduras	1473	Grenada
505	Nicaragua	1649	Turks and Caicos Islands
506	Costa Rica	1664	Montserrat
507	Panama	1670	Northern Mariana Islands
508	Saint Pierre and Miquelon	1671	Guam
509	Haiti	1684	American Samoa
590	Saint Martin	1758	Saint Lucia
592	Guyana	1767	Dominica
596	Martinique	1784	Saint Vincent and the Grenadines
673	Brunei	1868	Trinidad and Tobago
676	Tonga		
679	Fiji		
680	Palau		
681	Wallis and Futuna		
685	Samoa		
687	New Caledonia		
688	Tuvalu		
689	French Polynesia		
691	Federated States of Micronesia		
692	Marshall Islands		
855	Cambodia		
856	Laos		
880	Bangladesh		
960	Maldives		
961	Lebanon		
962	Jordan		
964	Iraq		
965	Kuwait		
966	Saudi Arabia		
967	Yemen		
968	Oman		
971	United Arab Emirates		
972	Israel		
973	Bahrain		
974	Qatar		
975	Bhutan		
976	Mongolia		
977	Nepal		

992	Tajikistan		
993	Turkmenistan		
994	Azerbaijan		

Indian data center: (<https://ind-cloud.ss-iot.com/login>)

Country code	Country or region
91	Indian

SIP or landline supported countries and regions:

Country	SIP Call (APP)	Landline (Phone)
Peru	√	√
Mexico	√	√
Argentina	√	√
Brazil	√	√
Chile	√	√
Columbia	√	√
Venezuela	√	√
Falkland Islands	√	√
Guatemala	√	√
Bolivia	√	√
Ecuador	√	√
French Guyana	√	√
Paraguay	√	√
Suriname	√	√
Uruguay	√	√
Nauru	√	√
Cook Islands	√	√
Niue Island	√	√
Kiribati	√	√
USA	√	√
Canada	√	√
Puerto Rico	√	√
Bahamas	√	√
Belize	√	√
El Salvador	√	√
Honduras	√	√
Nicaragua	√	√
Costa Rica	√	√
Panama	√	√
Saint Pierre	√	Not Support
Haiti	√	√
Guadeloupe	√	√
Guyana	√	√
Martinique	√	√
Aruba	√	√
Tuvalu	√	√
Greenland	√	√
Virgin Islands	√	√
Anguilla	√	√
Saint Lucia	√	Not Support
Barbados	√	√
Jamaica	√	√
Hong Kong, China	√	√
Macao China	√	√
Taiwan, China	√	√

Malaysia	√	√
Indonesia	√	√
Philippines	√	√
Thailand	√	√
Japan	√	√
Korea	√	√
Vietnam	√	√
Myanmar	√	√
Timor-Leste	√	√
Singapore	√	√
Sri Lanka	√	√
Brunei	√	√
Cambodia	√	√
Laos	√	√
Bangladesh	√	√
Maldives	√	√
Bhutan	√	√
Mongolia	√	√
Nepal	√	√
India	√	√
Russia	√	√
UK	√	√
Germany	√	√
Italy	√	√
France	√	√
Greece	√	√
Netherlands	√	√
Belgium	√	√
Spain	√	√
Hungary	√	√
Romania	√	√
Switzerland	√	√
Austria	√	√
Denmark	√	√
Sweden	√	√
Norway	√	√
Poland	√	√
San Marino	√	√
Hungary	√	√
Yugoslavia	√	√
Gibraltar	√	√
Portugal	√	√
Luxembourg	√	√
Ireland	√	√
Iceland	√	√
Albania	√	√
Malta	√	√
Finland	√	√
Bulgaria	√	√

Lithuania	√	√
Latvia	√	√
Estonia	√	√
Moldova	√	√
Andorra	√	√
Ukraine	√	√
Croatia	√	√
Slovenia	√	√
BiH	√	√
Macedonia	√	√
Czech Republic	√	√
Slovakia	√	√
Liechtenstein	√	√
Faroe Islands	√	√
Monaco	√	√
Palestine	√	√
Sao Tome	√	√
Principe	√	√
Guinea-Bissau	√	Not Support
Tajikistan	√	√
Türkiye	√	√
Pakistan	√	√
Afghanistan	√	√
Armenia	√	√
Lebanon	√	√
Jordan	√	√
Iraq	√	√
Kuwait	√	√
Saudi Arabia	√	√
Yemen	√	√
Oman	√	√
United Arab Emirates	√	√
Israel	√	√
Bahrain	√	√
Qatar	√	√
Turkmenistan	√	√
Azerbaijan	√	√
Georgia	√	√
Kyrgyzstan	√	√
Uzbekistan	√	√
Cyprus	√	√
Egypt	√	√
South Africa	√	√
Morocco	√	√
Algeria	√	√
Tunisia	√	√
Libya	√	√
Gambia	√	√
Senegal	√	√

Mauritania	√	√
Mali	√	√
Guinea	√	√
Cote d'Ivoire	√	√
Burkina Faso	√	√
Niger	√	√
Togo	√	√
Benin	√	√
Mauritius	√	√
Liberia	√	√
Sierra Leone	√	√
Ghana	√	√
Nigeria	√	√
Chad	√	√
Central African	√	√
Cameroon	√	√
Cape Verde	√	√
Equatorial Guinea	√	√
Gabon	√	√
Congo	√	√
Zaire	√	Not Support
Angola	√	√
Seychelles	√	√
Rwanda	√	√
Ethiopia	√	√
Somalia	√	√
Djibouti	√	√
Kenya	√	√
Tanzania	√	√
Uganda	√	√
Burundi	√	√
Mozambique	√	√
Zambia	√	√
Madagascar	√	√
Reunion Island	√	√
Zimbabwe	√	√
Namibia	√	√
Malawi	√	√
Lesotho	√	√
Botswana	√	√
Eswatini	√	√
Comoros	√	√
Eritrea	√	√
Vatican	√	√
New Zealand	√	√
Solomon Islands	√	√
Vanuatu	√	√
Australia	√	√
Tonga	√	√

Fiji	√	√
Western Samoa	√	√